

THE TOWN OF  
**Windermere**



**FOOD TRUCK / FARMERS MARKET SELECTION COMMITTEE**

Chair: Town Manager Robert  
Smith

Farmers Market / Windermere Tree

Board Liaison: Frank Krens

Food Truck / Historic Preservation

Board Liaison: Liz Andert

Farmers Market Coordinator:  
Robert Rinaldo

Food Truck Coordinator: Lilian  
Colli

Town Council Liaison: Mandy  
David

***Agenda***

***Agenda***

August 15, 2024  
10:30 AM

ADMINISTRATIVE CONFERENCE ROOM  
614 MAIN STREET, BUILDING 100  
WINDERMERE, FL 34786

PLEASE TURN OFF ALL CELL PHONES AND PAGERS

PLEASE NOTE: IN ACCORDANCE WITH F.S. 286.26: Person with disabilities needing assistance to participate in any such proceedings should contact the Office of the Clerk at least 48 hours beforehand at (407) 876-2563.

Pursuant to Resolution No. 2005-12 adopted on December 13, 2005, the following Civility Code shall govern all proceedings before the Town of Windermere Food Truck / Farmers Market Selection Committee:

1. All electronic devices, including cell phones and pagers. shall be either turned off or otherwise silenced.
2. Prolonged conversation shall be conducted outside Council meeting hall.
3. Whistling, heckling, gesturing, loud conversations, or other disruptive behavior is prohibited.
4. Only those individuals who have signed the speaker list and/or/who have been recognized by the Mayor (or Chair) may address comments to the Council.
5. Comments at public hearings shall be limited to the subject being considered by the Council
6. Comments at Open Forums shall be directed to Town issues.
7. All public comments shall avoid personal attacks and abusive language
8. No person attending a Food Truck / Farmers Market Selection Committee meeting is to harass, annoy, or otherwise disturb any other person in the room.

Any member of the public whose behavior is disruptive and violates the Town of Windermere Civility Code is subject to removal from the Food Truck / Farmers Market Selection Committee meeting by an officer and such other actions as may be appropriate. PLEASE NOTE: IN ACCORDANCE WITH F.S. 286.0105: Any person who desires to appeal any decision at this meeting will need a record of this proceeding. For this, such person may need to ensure that a verbatim record of such proceeding is made which includes the

## AGENDA

- 1. THE MEETING IS CALLED TO ORDER**
- 2. OPEN FORUM / PUBLIC COMMENT (3-Minute Limit)**
- 3. NEW BUSINESS**
  - a. New Applicants for Farmers Market / Pre-Approved (Attachments)**
    - i. Sally's Delectables**
    - ii. Alpa Chocolate**
    - iii. Atelie Cookies & More**
    - iv. David Cara Wood Creations**
    - v. Loganjade Designs**
    - vi. Ragazzi Firewood Pizza**
    - vii. Spotted Delights**

**b. New Applicants for Food Truck Night / Committee Option (Attachments)**

**i. Acas Cuisine**

**ii. Charm City Eats**

**iii. El Paladar Latino**

**iv. Fragaria Ice Cream**

**v. Let's Make It Saucy**

**vi. Pac Pizzeria**

**vii. Popcorn Fix**

**viii. Son Pastelitos FL**

**c. Food Truck Night 24/25 Sponsorship Opportunities (Attachments)**

**i. Sponsorship categories and prices**

**ii. New Banner with Diamond Sponsors**

**4. OTHER ITEMS FOR CONSIDERATION**

**a. Back to School Celebration**

**i. Lilian to Report (Attachments)**

**b. Upcoming Food Truck Nights**

**i. September 27th - National Night Out**

**ii. October 25th - Halloween Special**

**iii. November 22nd - Light Up Windermere!**

**iv. December 20th - Holiday Movie Special**

**- Due to holidays, it will be held on the 3rd Friday of the Month.**

**5. ADJOURN**



# WINDERMERE FARMERS MARKET VENDOR AGREEMENT

Name: Sally McFarland

Business Name (if applicable): Sally's Delectables

Address: 41124 Ponciava St

City: Eustis State: FL Zip: 32736

Telephone: 774-521-8485 EMAIL: Sallysdelectables@gmail.com

Description of Products:  
Italian Baked Cookies Biscottis

All Home made

I, the undersigned, have read the entire Vendor Information Packet governing the Windermere Farmer's Market, and agree to adhere to these guidelines. I understand that the market reserves the right to limit the participation of a vendor.

I agree to indemnify and hold harmless the Windermere Downtown Business Committee, City of Windermere, River City Events and Gatherings, LLC and its agents, employees and volunteers from any liability, cost, damages, and other expenses suffered or incurred during the Market.

The market is not responsible for any vendors' property at the market, nor is it responsible for any liability arising from the negligent acts of vendors or their employees or for any injuries sustained by employees of and/or vendors. In the event the market is sued for any negligent acts of a vendor or his/her employees, the market's insurance will subrogate against a said vendor for the full amount of any loss paid.

I understand that I am responsible for adhering to all relevant government regulations e.g. health codes, licenses, etc.

Vendor Signature: Sally McFarland Date: 2/11/23

Please email to:

Farmersmarket407@gmail.com

Please attach any license required for your business to this application along with photos.

## Lilian Colli

---

**From:** Robert MR <farmersmarket407@gmail.com>  
**Sent:** Friday, July 5, 2024 10:29 AM  
**To:** Lilian Colli  
**Subject:** Re: Photos of Biscottis

They operate under the cottage, food act. There is no documentation required as long as they have the proper labeling on their product only but again the cottage fruit act allows people to bake goods at home and sell them to the public as long as they are not perishable And do not require heat or cold these Biscotti's fall under the cottage food act It can be a little confusing. Hope this helps. Thank you, Robert.

On Fri, Jul 5, 2024 at 9:34 AM Lilian Colli <[lcolli@town.windermere.fl.us](mailto:lcolli@town.windermere.fl.us)> wrote:

Good morning.

I do not have the application, business registration and license.

Thanks,

## Lilian Colli

***Administrative Assistant***

1(407) 909-5327

[lcolli@town.windermere.fl.us](mailto:lcolli@town.windermere.fl.us)

614 Main Street  
Windermere, FL 34786









# WINDERMERE FARMERS MARKET VENDOR AGREEMENT

Name: Patricia Christodulidis

Business Name (if applicable): Alpa Chocolate

Address: 1726 Maple Leaf Drive

City: Windermere State: FL Zip: 34786

Telephone: 309-253-0641 EMAIL pat.christodulidis@gmail.com

### Description of Products:

Single origin craft chocolate Bars, organic, traceable, no additives (no soy, no chemicals, no aromas) dark, milk, white, with or without inclusions.

Some special packaging for Holidays ie Gift Boxes

I, the undersigned, have read the entire Vendor Information Packet governing the Windermere Farmer's Market, and agree to adhere to these guidelines.

I understand that the market reserves the right to limit the participation of a vendor.

I agree to indemnify and hold harmless the Windermere Downtown Business Committee, City of Windermere, River City Events and Gatherings, LLC and its agents, employees and volunteers from any liability, cost, damages, and other expenses suffered or incurred during the Market.

The market is not responsible for any vendors' property at the market, nor is it responsible for any liability arising from the negligent acts of vendors or their employees or for any injuries sustained by employees of and/or vendors. In the event the market is sued for any negligent acts of a vendor or his/her employees, the market's insurance will subrogate against a said vendor for the full amount of any loss paid.

I understand that I am responsible for adhering to all relevant government regulations e.g. health codes, licenses, etc.

Vendor Signature:  Date: 6/8/2024

Please email to:

Farmersmarket407@gmail.com

Please attach any license required for your business to this application along with photos.



	<b>2023</b>		<b>EXPIRES 9/30/2024</b>	3501-1238942
3501 COTTAGE FOODS	\$30.00		1 EMPLOYEE	

TOTAL TAX	\$30.00
PREVIOUSLY PAID	\$30.00
TOTAL DUE	\$0.00

CHRISTODULIDIS PATRICIA L

ALPA CHOCOLATE  
 CHRISTODULIDIS PATRICIA L  
 1726 MAPLE LEAF DR  
 WINDERMERE FL 34786

1726 MAPLE LEAF DR (MOBILE)  
U - WINDERMERE, 34786

PAID: \$30.00 0098-01103931 7/10/2023

**Tax Collector Scott Randolph**

**Local Business Tax Receipt**

This local Business Tax Receipt is in addition to and not in lieu of any other tax required by law or municipal ordinance. Businesses are subject to regulation of zoning, health and other lawful authorities. This receipt is valid from October 1 through September 30 of receipt year. **Delinquent penalty is added October 1.**

	<b>2023</b>		<b>EXPIRES 9/30/2024</b>	3501-1238942
3501 COTTAGE FOODS	\$30.00		1 EMPLOYEE	

TOTAL TAX	\$30.00
PREVIOUSLY PAID	\$30.00
TOTAL DUE	\$0.00



CHRISTODULIDIS PATRICIA L

ALPA CHOCOLATE  
 CHRISTODULIDIS PATRICIA L  
 1726 MAPLE LEAF DR  
 WINDERMERE FL 34786

1726 MAPLE LEAF DR (MOBILE)  
U - WINDERMERE, 34786

PAID: \$30.00 0098-01103931 7/10/2023

This receipt is official when validated by the Tax Collector.

Orange County Code requires this local Business Tax Receipt to be displayed conspicuously at the place of business in public view. It is subject to inspection by all duly authorized officers of the County.



Halloween at Dr. Phillips' Market



Everybody gets a sample



Valentine's at Dr. Phillips Market

alpa



Christmas at Celebration's Art Market





Special Christmas Bar



Christmas Time at Dr. Phillips' Market

alpaca



Christmas Inclusions

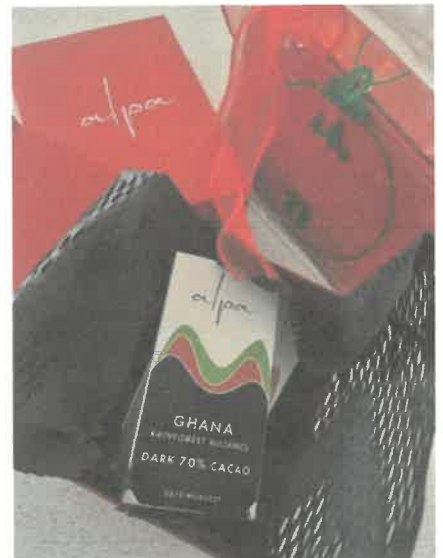

Christmas Gift Box



# WINDERMERE FARMERS MARKET VENDOR AGREEMENT

Name: CAIO GIANOTTI e ELIS GIANOTTI

Business Name (if applicable): Atelie Cookies & more.

Address: 15065 Status Loop

City: Winter Garden State: FL Zip: 34787

Telephone: 689 293 1209 EMAIL ATELIE COOKIES @ Outlook . Com

Description of Products:

BAGZIUM SWEETS - FLAN - BRIGADEIROS

- COOKIES - CREME BRÛLÉE

I, the undersigned, have read the entire Vendor Information Packet governing the Windermere Farmer's Market, and agree to adhere to these guidelines.

I understand that the market reserves the right to limit the participation of a vendor.

I agree to indemnify and hold harmless the Windermere Downtown Business Committee, City of Windermere, River City Events and Gatherings, LLC and its agents, employees and volunteers from any liability, cost, damages, and other expenses suffered or incurred during the Market.

The market is not responsible for any vendors' property at the market, nor is it responsible for any liability arising from the negligent acts of vendors or their employees or for any injuries sustained by employees of and/or vendors. In the event the market is sued for any negligent acts of a vendor or his/her employees, the market's insurance will subrogate against a said vendor for the full amount of any loss paid.

I understand that I am responsible for adhering to all relevant government regulations e.g. health codes, licenses, etc.

Vendor Signature: \_\_\_\_\_

Date: 10/04/23

Please email to:

Farmersmarket407@gmail.com

Please attach any license required for your business to this application along with photos.





# ATELIE COOKIES & MORE



WINTER GARDEN - FL

## Cookies

Belgian Dark chocolate	\$3,50
Belgian Milk chocolate	\$3,50
Belgian White chocolate	\$3,50
Ninho com Nutela	\$3,50
White and black	\$3,50
Oreo	\$3,50
Red Velvet	\$3,50
<b>Box Combos (6unid)</b>	<b>\$18,00</b>

## Brigadeiros

Belgian Dark chocolate	\$1.50
Belgian Milk chocolate	\$1.50
Belgian White chocolate	\$1.50
Creme Brulle	\$1.50
Ninho com Nutela	\$1.50
Peanut / Paçoquinha	\$1.50
Coconut / Beijinho	\$1,50
Dois amores/White and black	\$1,50
Oreo	\$1,50
<b>Box Combos (6 unid)</b>	<b>\$7,00</b>
<b>Box Combos (15 unid)</b>	<b>\$15,00</b>

## Pudim/Flan

150g/0,33lbs	\$4,50
500g/1,10lbs	\$18.00
1.100g/2,42lbs	\$29,90

FOR DELIVERY,  
CONTACT +689-293-1209

 [ateliedobrigadeiro\\_](https://www.instagram.com/ateliedobrigadeiro_)

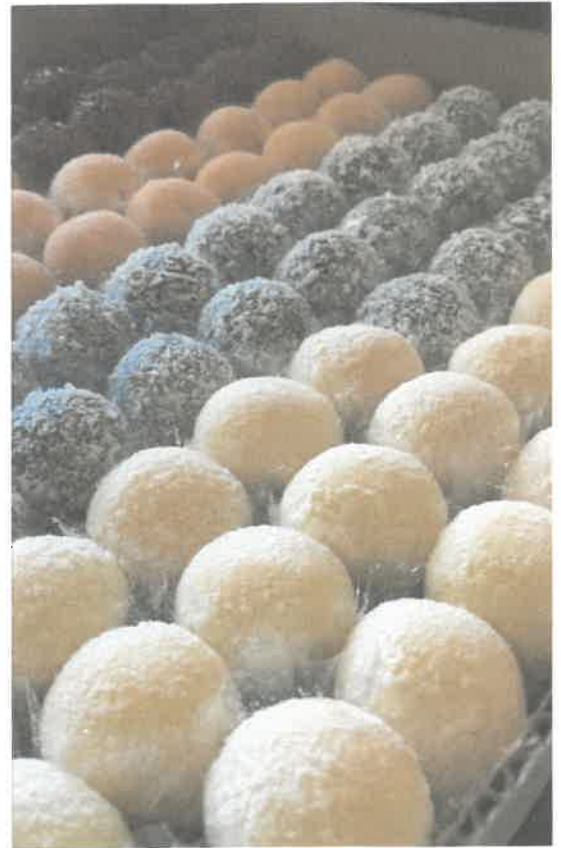
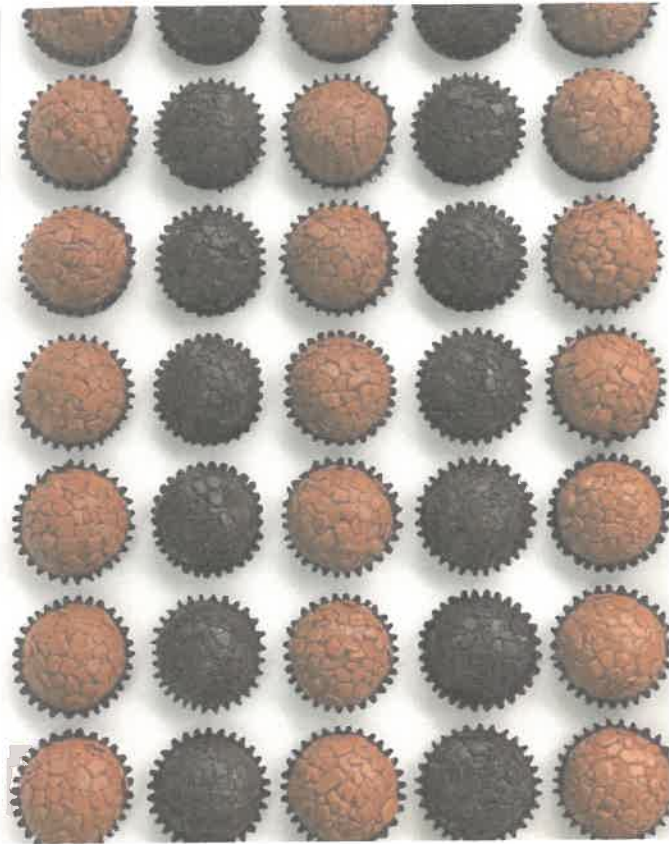



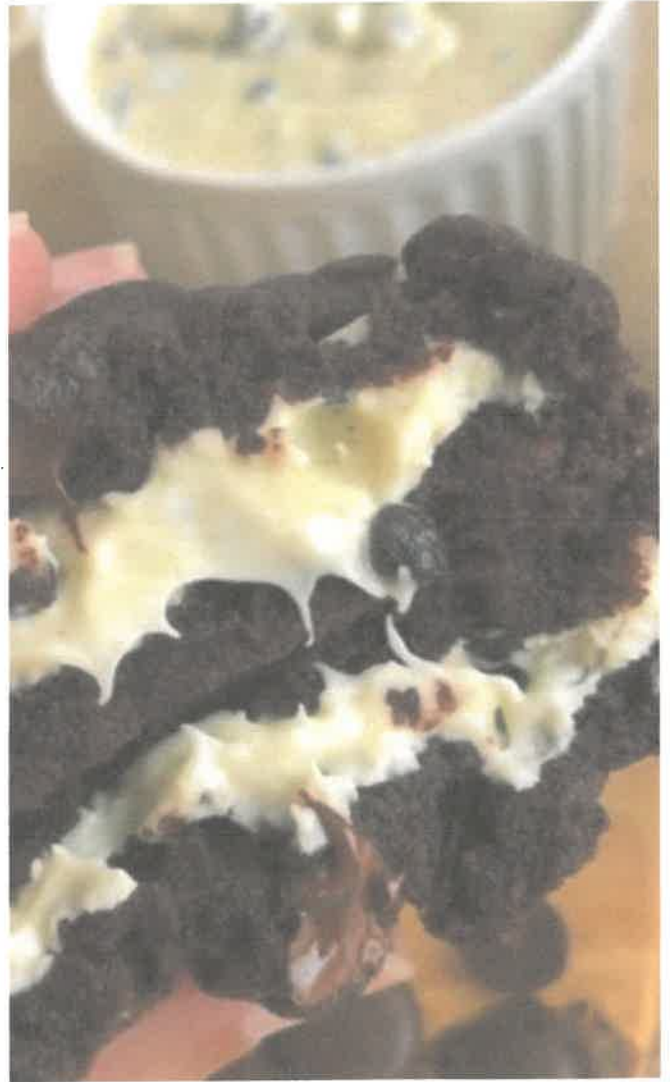

Date of this notice: 09-25-2023

Employer Identification Number:  
93-3568491

Form: SS-4

Number of this notice: CP 575 B

AHELIE COOKIES & MORE LLC  
ELIS REGINA SCHORR SANTOS GIANOTTI AMBR  
15065 STRATUS LOOP APT 101  
WINTER GARDEN, FL 34787

For assistance you may call us at:  
1-800-829-4933

IF YOU WRITE, ATTACH THE  
STUB AT THE END OF THIS NOTICE.

WE ASSIGNED YOU AN EMPLOYER IDENTIFICATION NUMBER

Thank you for applying for an Employer Identification Number (EIN). We assigned you EIN 93-3568491. This EIN will identify you, your business accounts, tax returns, and documents, even if you have no employees. Please keep this notice in your permanent records.

Taxpayers request an EIN for their business. Some taxpayers receive CP575 notices when another person has stolen their identity and are opening a business using their information. If you did **not** apply for this EIN, please contact us at the phone number or address listed on the top of this notice.

When filing tax documents, making payments, or replying to any related correspondence, it is very important that you use your EIN and complete name and address exactly as shown above. Any variation may cause a delay in processing, result in incorrect information in your account, or even cause you to be assigned more than one EIN. If the information is not correct as shown above, please make the correction using the attached tear-off stub and return it to us.

Based on the information received from you or your representative, you must file the following forms by the dates shown.

Form 1065

03/15/2024

If you have questions about the forms or the due dates shown, you can call us at the phone number or write to us at the address shown at the top of this notice. If you need help in determining your annual accounting period (tax year), see Publication 538, *Accounting Periods and Methods*.

We assigned you a tax classification (corporation, partnership, estate, trust, EPMF, etc.) based on information obtained from you or your representative. It is not a legal determination of your tax classification, and is not binding on the IRS. If you want a legal determination of your tax classification, you may request a private letter ruling from the IRS under the guidelines in Revenue Procedure 2020-1, 2020-1 I.R.B. 1 (or superseding Revenue Procedure for the year at issue). Note: Certain tax classification elections can be requested by filing Form 8832, *Entity Classification Election*. See Form 8832 and its instructions for additional information.

A limited liability company (LLC) may file Form 8832, *Entity Classification Election*, and elect to be classified as an association taxable as a corporation. If the LLC is eligible to be treated as a corporation that meets certain tests and it will be electing S corporation status, it must timely file Form 2553, *Election by a Small Business Corporation*. The LLC will be treated as a corporation as of the effective date of the S corporation election and does not need to file Form 8832.



# State of Florida Department of State

I certify from the records of this office that ATELIE COOKIES & MORE, LLC, is a limited liability company organized under the laws of the State of Florida, filed electronically on September 20, 2023, effective September 20, 2023.

The document number of this company is L23000438589.

I further certify that said company has paid all fees due this office through December 31, 2023, and its status is active.

I further certify that this is an electronically transmitted certificate authorized by section 15.16, Florida Statutes, and authenticated by the code noted below.

Authentication Code: 230922094444-600416077676#1

Given under my hand and the  
Great Seal of the State of Florida  
at Tallahassee, the Capital, this the  
Twenty Second day of September, 2023



  
Cord Byrd  
Secretary of State

**Electronic Articles of Organization  
For  
Florida Limited Liability Company**

L23000438589  
FILED 8:00 AM  
September 20, 2023  
Sec. Of State  
grkersey

**Article I**

The name of the Limited Liability Company is:

ATELIE COOKIES & MORE, LLC

**Article II**

The street address of the principal office of the Limited Liability Company is:

15065 STRATUS LOOP  
APT 101  
WINTER GARDEN, FL. US 34787

The mailing address of the Limited Liability Company is:

15065 STRATUS LOOP  
APT 101  
WINTER GARDEN, FL. US 34787

**Article III**

Other provisions, if any:

ANY AND ALL LAWFULL BUSINESS.

**Article IV**

The name and Florida street address of the registered agent is:

CAIO GIANOTTI  
15065 STRATUS LOOP  
APT 101  
WINTER GARDEN, FL. 34787

Having been named as registered agent and to accept service of process for the above stated limited liability company at the place designated in this certificate, I hereby accept the appointment as registered agent and agree to act in this capacity. I further agree to comply with the provisions of all statutes relating to the proper and complete performance of my duties, and I am familiar with and accept the obligations of my position as registered agent.

Registered Agent Signature: CAIO GIANOTTI



**Article V**

The name and address of person(s) authorized to manage LLC:

Title: AMBR  
ELIS REGINA S SANTOS GIANOTTI  
15065 STRATUS LOOP, APT 101  
WINTER GARDEN, FL. 34787 US

Title: AMBR  
CAIO GIANOTTI  
15065 STRATUS LOOP, APT 101  
WINTER GARDEN, FL. 34787 US

L23000438589  
FILED 8:00 AM  
September 20, 2023  
Sec. Of State  
grkersey

**Article VI**

The effective date for this Limited Liability Company shall be:

09/20/2023

Signature of member or an authorized representative

Electronic Signature: ROSI LUCE ALVES

I am the member or authorized representative submitting these Articles of Organization and affirm that the facts stated herein are true. I am aware that false information submitted in a document to the Department of State constitutes a third degree felony as provided for in s.817.155, F.S. I understand the requirement to file an annual report between January 1st and May 1st in the calendar year following formation of the LLC and every year thereafter to maintain "active" status.

# WINDERMERE FARMERS MARKET VENDOR AGREEMENT

Name: David and Cara Showers

Business Name (if applicable): DavidCara Wood Creations

Address: 180 E. Goodheart Avenue

City: Lake Mary State: Florida Zip: 32746

Phone: David: 407-617-1699 • Cara: 407-782-4072 Email: contact@davidcara.com

Description of Products:

Wooden jewelry, such as: earrings, bracelets, hair claw clips, necklaces, key chains, pins, magnets, etc. Every item we make is made of wood or has wood in it. Home decor items, such as: laser art, wooden art, coasters, bookmarks, dishes, photo engraving, jewelry boxes, American flags, holiday decorations, door signs, garden/yard art, eyeglass holders, pocket hugs, custom wood projects, etc.

I, the undersigned, have read the entire Vendor Information Packet governing the Windermere Farmer's Market, and agree to adhere to these guidelines.

I understand that the market reserves the right to limit the participation of a vendor.

I agree to indemnify and hold harmless the Windermere Downtown Business Committee, City of Windermere, River City Events and Gatherings, LLC and its agents, employees and volunteers from any liability, cost, damages, and other expenses suffered or incurred during the Market.

The market is not responsible for any vendors' property at the market, nor is it responsible for any liability arising from the negligent acts of vendors or their employees or for any injuries sustained by employees of and/or vendors. In the event the market is sued for any negligent acts of a vendor or his/her employees, the market's insurance will subrogate against a said vendor for the full amount of any loss paid.

I understand that I am responsible for adhering to all relevant government regulations e.g. health codes, licenses, etc.

Vendor Signature: \_\_\_\_\_

Date: 6/24/24

Please email to:

Farmersmarket407@gmail.com

Please attach any license required for your business to this application along with photos.









# APPLICATION FOR REGISTRATION OF FICTITIOUS NAME

REGISTRATION# G22000141092

**Fictitious Name to be Registered:** DAVIDCARA WOOD CREATIONS

**Mailing Address of Business:** 180 E GOODHEART AVE  
LAKE MARY, FL 32746

**Florida County of Principal Place of Business:** SEMINOLE

**FEI Number:**

**FILED**  
**Nov 13, 2022**  
**Secretary of State**

**Owner(s) of Fictitious Name:**

GRAYBEARD WOOD SHOP LLC  
180 E GOODHEART AVE  
LAKE MARY, FL 32746  
Florida Document Number: L21000484764  
FEI Number: 87-3577983

I the undersigned, being an owner in the above fictitious name, certify that the information indicated on this form is true and accurate. I further certify that the fictitious name to be registered has been advertised at least once in a newspaper as defined in Chapter 50, Florida Statutes, in the county where the principal place of business is located. I understand that the electronic signature below shall have the same legal effect as if made under oath and I am aware that false information submitted in a document to the Department of State constitutes a third degree felony as provided for in s. 817.155, Florida Statutes.

DAVID M SHOWERS

11/13/2022

Electronic Signature(s)

Date

**Certificate of Status Requested (X)**

**Certified Copy Requested (X)**



**2023 - 2024**

City of Lake Mary  
Post Office Box 958445, Lake Mary, FL 32795-8445

**LOCAL BUSINESS TAX**

LOCATION: 180 E GOODHEART AVE

Classification: GENERAL SVC. PROVIDER, NO STATE LICENSE

For: GRAYBEARD WOOD SHOP LLC  
180 E GOODHEART AVE  
LAKE MARY FL 32746

Comments: WOOD WORK. SUBJ TO F.S. 559.955

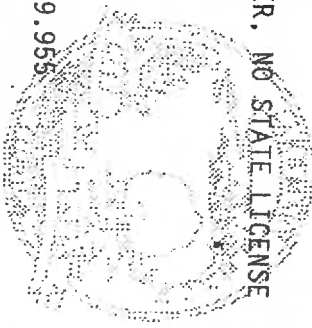

Receipt # 24 00010461

THIS RECEIPT MUST BE POSTED  
CONSPICUOUSLY IN YOUR PLACE OF  
BUSINESS.

*This receipt expires 9/30/24.*

Receipt Fee	\$	50.00
Delinquent Penalty	\$	.00
Interest	\$	.00

**TOTAL \$ 50.00**

*Michelle McCurdy*  
City Clerk

**BUSINESS SHALL COMPLY WITH ALL CITY CODES OR BE SUBJECT TO NON-RENEWAL OR REVOCATION.**  
**BY THE ISSUANCE OF THIS BUSINESS TAX RECEIPT, THE CITY IS NOT APPROVING THE USE OF THE PROPERTY OR THAT THE PROPERTY IS COMPLIANT WITH CODE IN ANY WAY.**



# WINDERMERE FARMERS MARKET VENDOR AGREEMENT

Name: Patricia McCory

Business Name (if applicable): Loganjade Designs

Address: 8548 Sugar Palm Ct

City: Orlando State: FL Zip: 32835

Telephone: 407 963-8737 EMAIL cmac1992@hotmail.com

Description of Products: Women's Embellished Clothing

1. Tunic sets with custom matching designs on top and bottom. 2. Custom collar sweatshirts with embroidered designs and adjustable cuffs. Displayed on tables, hung on racks and hung on inside of tent area. All items are designed and hand created by myself. See pictures.

I, the undersigned, have read the entire Vendor Information Packet governing the Windermere Farmer's Market, and agree to adhere to these guidelines.

I understand that the market reserves the right to limit the participation of a vendor.

I agree to indemnify and hold harmless the Windermere Downtown Business Committee, City of Windermere, River City Events and Gatherings, LLC and its agents, employees and volunteers from any liability, cost, damages, and other expenses suffered or incurred during the Market.

The market is not responsible for any vendors' property at the market, nor is it responsible for any liability arising from the negligent acts of vendors or their employees or for any injuries sustained by employees of and/or vendors. In the event the market is sued for any negligent acts of a vendor or his/her employees, the market's insurance will subrogate against a said vendor for the full amount of any loss paid.

I understand that I am responsible for adhering to all relevant government regulations e.g. health codes, licenses, etc.

Vendor Signature: Patricia McCory Date: 06/15/24

Please email to:

Farmersmarket407@gmail.com

Please attach any license required for your business to this application along with photos.







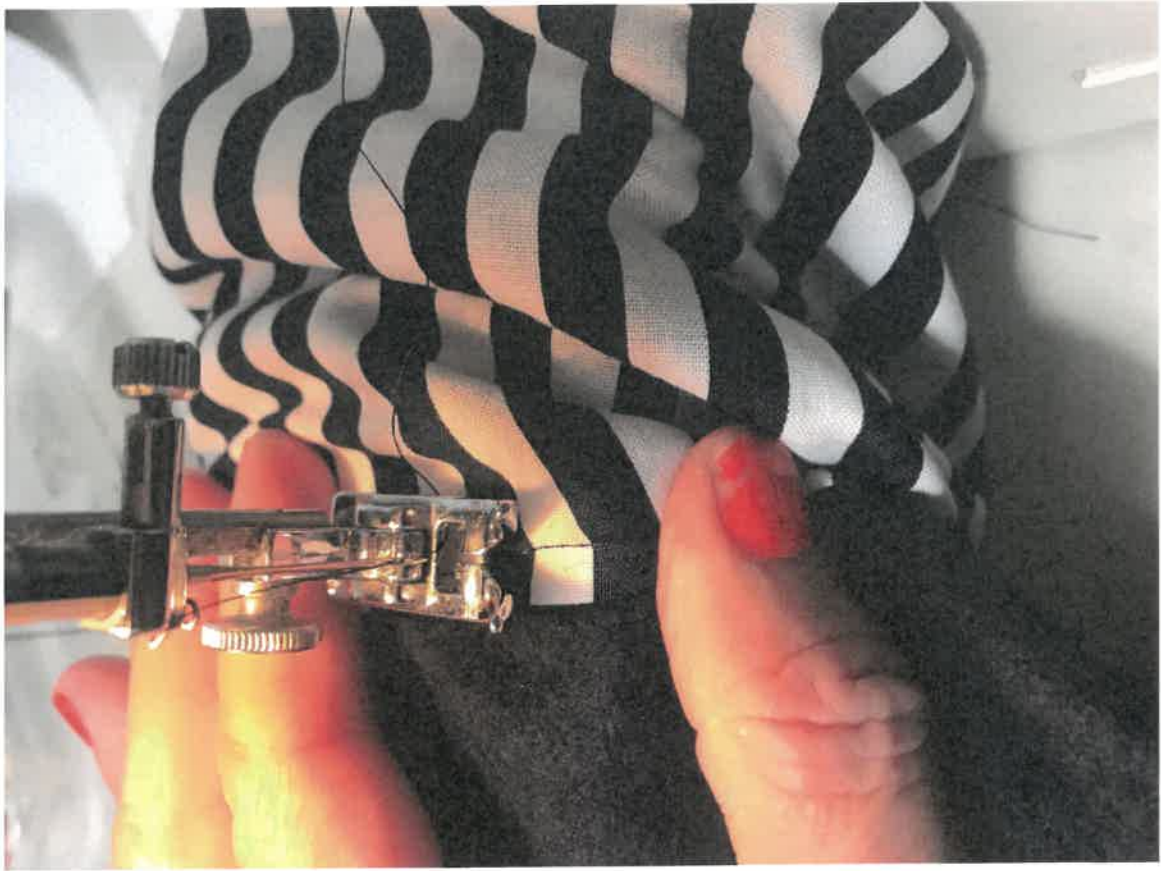



# WINDERMERE FARMER S MARKET v ENDOR AGREEMENT

Name: **Alejandro Abreu**

Business Name (if applicable): **RAGAZZI'S ON THE GO**

Address: 3201 Edgewater Dr

City: **Orlando** State: **Florida** Zip: **32804**

Telephone: **321.948.5655** EMAIL [contact@ragazzis.net](mailto:contact@ragazzis.net)

Description of **Products**:

**Fresh firewood Calzone, Stromboli, focaccia and Panini**

---

I, the undersigned, have read the entire Vendor Information Packet governing the Windermere Farmer's Market, and agree to adhere to these guidelines.

I understand that the market reserves the right to limit the participation of a vendor.

I agree to indemnify and hold harmless the Windermere Downtown Business Committee, City of Windermere, River City Events and Gatherings, LLC and its agents, employees and volunteers from any liability, cost, damages, and other expenses suffered or incurred during the Market.

The market is not responsible for any vendors' property at the market, nor is it responsible for any liability arising from the negligent acts of vendors or their employees or for any injuries sustained by employees of and/or vendors. In the event the market is sued for any negligent acts of a vendor or his/her employees, the market's insurance will subrogate against a said vendor for the full amount of any loss paid.

I understand that I am responsible for adhering to all relevant government regulations e.g. health codes, licenses, etc.

Vendor Signature: Alejandro Abreu Date: April 11 2024

Please email to:

Farmersmarket407@gmail.com

Please attach any license required for your business to this application along with photos.





Ron Desantis, Governor

Melanie S. Griffin, Secretary



**STATE OF FLORIDA  
DEPARTMENT OF BUSINESS AND PROFESSIONAL REGULATION**

**DIVISION OF HOTELS AND RESTAURANTS**

THE SEATING FOOD SERVICE (2010) HEREIN IS LICENSED UNDER THE  
PROVISIONS OF CHAPTER 509, FLORIDA STATUTES  
NBR. OF SEATS: 154

**GOTO INVESTMENTS CORP**  
RAGAZZI'S PIZZA & RESTAURANT  
3201 EDGEWATER DR  
ORLANDO FL 32804

**LICENSE NUMBER: SEA5812645**

**EXPIRATION DATE: APRIL 1, 2025**

Always verify licenses online at [MyFloridaLicense.com](http://MyFloridaLicense.com)

ISSUED: 05/13/2024

Do not alter this document in any form.

This is your license. It is unlawful for anyone other than the licensee to use this document.





Ron DeSantis, Governor

Melanie S. Griffin, Secretary



**STATE OF FLORIDA  
DEPARTMENT OF BUSINESS AND PROFESSIONAL REGULATION**

**DIV OF ALCOHOLIC BEVERAGES & TOBACCO**

THE RETAILER OF ALCOHOLIC BEVERAGES HEREIN IS LICENSED UNDER THE  
PROVISIONS OF CHAPTER 561, FLORIDA STATUTES

SERIES: 4COP TYPE: SFS  
CONSUMPTION ON PREMISES ONLY

**GOTO INVESTMENTS CORP**

RAGAZZI'S PIZZA AND RESTAURANT  
3201 EDGEWATER DR  
ORLANDO FL 32804

**LICENSE NUMBER: BEV5810931**

**EXPIRATION DATE: SEPTEMBER 30, 2024**

Always verify licenses online at [MyFloridaLicense.com](http://MyFloridaLicense.com)

ISSUED: 05/13/2024

Do not alter this document in any form.

This is your license. It is unlawful for anyone other than the licensee to use this document.



# 2023 - 2024



## Local Business Tax Receipt

(Formerly known as "Business License "  
changed per state law HB1269-2006)

**Business Name**  
RAGAZZIS PIZZA & RESTAURANT  
3201 EDGEWATER DR  
ORLANDO, FL 32804

**Business Owner**  
GOTO INVESTMENTS CORP

**Business Location**  
3201 EDGEWATER DR  
ORLANDO, FL

**NOTICE-THIS TAX RECEIPT ONLY EVIDENCES PAYMENT OF THE LOCAL BUSINESS TAX PURSUANT TO CH.205, FLORIDA STATUTES. IT DOES NOT PERMIT THE HOLDER TO OPERATE IN VIOLATION OF ANY CITY, STATE, OR FEDERAL LAW. CITY PERMITTING MUST BE NOTIFIED OF ANY MATERIAL CHANGE TO THE INFORMATION FOUND HEREIN BELOW. THIS RECEIPT DOES NOT CONSTITUTE AN ENDORSEMENT OR APPROVAL OF THE HOLDER'S SKILL OR COMPETENCY.**

**Case Number:** BUS-0026828

**Issued Date:** 10/04/2023

**Expiration Date:** 09/30/2024

### Business type(s):

<u>Description</u>	<u>Year</u>
RESTAU 5812 RESTAURANT	2024









# WINDERMERE FARMERS MARKET VENDOR AGREEMENT

Name: Douglas Caldes

Business Name (if applicable): Spotted Delights LLC

Address: 1425 Horizon Ct

City: Belle Isle State: FL Zip: 32809

Telephone: 407-963-6625 EMAIL: spotteddelightsllc@gmail.com

Description of Products: Freeze Dried Candy

I, the undersigned, have read the entire Vendor Information Packet governing the Windermere Farmer's Market, and agree to adhere to these guidelines.  
I understand that the market reserves the right to limit the participation of a vendor.

I agree to indemnify and hold harmless the Windermere Downtown Business Committee, City of Windermere, River City Events and Gatherings, LLC and its agents, employees and volunteers from any liability, cost, damages, and other expenses suffered or incurred during the Market.

The market is not responsible for any vendors' property at the market, nor is it responsible for any liability arising from the negligent acts of vendors or their employees or for any injuries sustained by employees of and/or vendors. In the event the market is sued for any negligent acts of a vendor or his/her employees, the market's insurance will subrogate against a said vendor for the full amount of any loss paid.

I understand that I am responsible for adhering to all relevant government regulations e.g. health codes, licenses, etc.

Vendor Signature: Douglas Caldes Date: 7-15-24

Please email to:

Farmersmarket407@gmail.com

Please attach any license required for your business to this application along with photos.



## **SPOTTED DELIGHTS**

- Spotted Delights sells a variety of freeze dried candies.  
Skittles, Bit of Honey, Nerds, Jolly Ranchers, Gummi Bears etc.
- We display in wire baskets sitting on the table.
- We use a white 10x10 canopy
- We use table cloths on our tables
- Products are made in a cottage food operation that is not subject to Florida's food safety regulations.

Information:

[www.spotteddelightsllc.com](http://www.spotteddelightsllc.com)

[www.instagram.com/Spotteddelightsllc](http://www.instagram.com/Spotteddelightsllc)

1425 Horizon Ct.  
Belle Isle Florida  
407-963-6625



**Spotted Delights LLC**  
**FREEZE DRIED CANDY**



[www.spotteddelightsllc.com](http://www.spotteddelightsllc.com)







## CITY OF BELLE ISLE

### BUSINESS TAX LICENSE

1600 Nela Avenue  
Belle Isle, FL 32809

**Business License Number:** L4-00470  
**Effective Date:** 05/08/24  
**Expiration Date:** 09/30/24  
**Fee:** 40.00

**Business Name:** SPOTTED DELIGHTS LLC  
**Location:** 1425 HORIZON CT  
**Classification:** SELL FREEZZE DRIED PRODUCT

**POST IN A CONSPICUOUS PLACE  
NOT VALID UNLESS SIGNED BY CITY OFFICIAL**

The person, firm, or corporation named above is hereby granted this license as the receipt for fees paid to the City of Belle Isle for the business described above for the period indicated. Granting of this certificate does not entitle the holder to operate or maintain a business in violation of any law or ordinance. The City of Belle Isle does not guarantee the qualifications of the holder of this certificate.

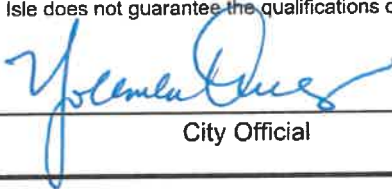
  
\_\_\_\_\_  
City Official

### BUSINESS TAX LICENSE

City of Belle Isle  
1600 Nela Avenue  
Belle Isle, FL 32809  
Phone: 407-851-7730 Fax 407-240-2222  
[www.cityofbelleislefl.org](http://www.cityofbelleislefl.org)



614 Main St. Windermere, FL 34786  
Office: (407) 876-2563 Fax: (407) 876-0103

## WINDERMERE FOOD TRUCK VENDOR APPLICATION

Owner Name: Abraham Perdomo Truck Name: Acas Cuisine

Address: 1121 Darnaby Way, Orlando FL 32824

Email: Acascuisinellc@gmail.com Primary Phone: (407) 633-2031

Thank you for your interest in the Town of Windermere Family Food Truck Events. The event is organized and owned by the Town of Windermere.

*Please read and review the rules and regulations for the event prior to completing this application.*

### PLEASE INITIAL EACH STATEMENT & SIGN

A \$150 fee is due no later than one (1) week prior to each Windermere Food Truck event, and is payable by credit card (Visa, MasterCard, or Discover. American Express not accepted). Credit Card Authorization Forms can be obtained from Finance Clerk Theresa Syphers ([tsyphers@town.windermere.fl.us](mailto:tsyphers@town.windermere.fl.us)). The Town does not keep these forms on file. A new form will need to be submitted for each event. It is the sole responsibility of the vendor to provide accurate and current payment information; Windermere is not responsible for any overdraft or overage fees associated with the card on file. Late payments will result in additional fees, and too many will result in impact ability to participate in future events.

A A copy of your Certificate of Liability Insurance with the Town of Windermere (614 Main Street, Windermere, FL 34786) listed as the Certificate Holder, Local Business Tax Receipt, and State of Florida Mobile Food Dispensing Vehicle License will be due upon approval.

A Vendor is required to provide a trash can with a lid. Removal of trash and cleaning in your area is required, even if it is not yours.

A Arrival time is 3:00pm. The set-up must wait until all trucks are in place. Trucks will be staged in designated areas prior to entering event space. Please do not arrive prior to 3:00pm; the weekly Farmers Market will be breaking down and early arrival will cause congestion and delays.



614 Main St. Windermere, FL 34786  
Office: (407) 876-2563 Fax: (407) 876-0103

A Vendor is to provide their own power supply; either to connect to the Town's electrical supplier via quiet/silent generator. All power cords that are in the service area must be secured to the ground to avoid accidents per Florida State Law. Please ensure your cord is the appropriate length.

A If a vendor wishes to connect to the Town's power, the vendor must identify the amount of amperage needed to run the Truck during the event. **Please review the attachment for the appropriate plug and amp size.** We also have a 20 amp that utilizes the standard 3 prong plug. It is the Vendor's responsibility to ensure they have the correct plug and to understand their own power needs. The Town will not be responsible for any damage caused by power.

A Prior to 4:30pm: Should a Vendor arrive without the appropriate hookups, is unable to connect to the Town's power supply, they will be asked to leave the event. Should this occur after 4:30 pm, the Vendor will need to close their Truck and not allow service. They will not be allowed to remove their Truck until after the event has ended.

A Service time will begin at either 5pm or 6pm depending on the month. Generally, the only month that will begin at 5pm is November. Town Staff will advise us of each month's start time. All events will run until 9:30pm.

A Each truck should be prepared to serve approximately 250 -300 people. Packing and cleaning up is permitted if you sell out prior to 9:30pm. Trucks must remain lit and accessible to optimize a professional look. The event ends at 9:30pm. It is the Vendor's responsibility to ensure they are not preparing/serving food or collecting payments after 9:30pm. Habitual disregard will affect ability to participate in future events.

A Each vendor must collect 6.5% on all taxable sales.

A The Town of Windermere reserves the right to alter scheduled dates, rotations, Truck participation, and Truck availability based on cuisine, amperage, and conduct of participants.

A If a truck is scheduled for a Town of Windermere Food Truck Night event, and cannot attend for any reason, it is the Vendor's responsibility to find a suitable replacement. Ms. Lilian Colli will provide you with a contact list. When a replacement is found, the original Truck will call or email Ms. Lilian Colli at [lcolli@town.windermere.fl.us](mailto:lcolli@town.windermere.fl.us) or 407-876-2563 ext. 5327 for final approval. The replacement Truck must be cleared by Town Staff **AND** must be a Windermere-approved truck.

A Replacement trucks are to pay the Town their \$150 fee directly. Replacement trucks should not make payments to the truck they are replacing. The Town will refund the replaced truck.





614 Main St. Windermere, FL 34786  
Office: (407) 876-2563 Fax: (407) 876-0103

A If a truck is scheduled for a Windermere Food Truck Night Event, and fails to show up, or does not find a suitable replacement, that truck forfeits their \$150 fee to the Town of Windermere.

A Each Truck is responsible for knowing and adhering to the rules set forth in this agreement. Parking is available on a first come-first serve basis. **NO PARKING IS ASSIGNED.**

A Events are rain or shine. In the rare instance that an event is cancelled, the Town Manager will determine whether trucks will be refunded or not be charged for their next scheduled event.

A Vendor shall indemnify and hold the Town of Windermere, its employees, agents, officials, and contractors, harmless from and against any and all claims, including, without limitation to, attorney's fees (whether incurred before during, or after trial, or upon appellate level) arising from the Vendor's participation in event.

The process after receiving an invite to a specific event date (after being selected by the Selection Committee) is as follows:

- Once your truck has been approved by the committee, Lilian Colli will contact you for any missing information such as liability insurance or business license.
- Truck Approval lists are updated monthly after each selection meeting. Town Staff will send out availability emails quarterly (December, March, June, and September).
- Schedules are created on a QUARTERLY basis (every three months). **Trucks can expect to be invited to an event zero to one event per quarter due to the high volume of trucks approved by the Town of Windermere Selection Committee.**

**I ACKNOWLEDGE THAT I HAVE READ AND UNDERSTAND THE TERMS AND CONDITIONS AS SET FORTH IN THIS APPLICATION TO PARTICIPATE IN WINDERMERE FOOD TRUCK EVENTS, AND I AGREE TO ALL STATEMENTS.**

Applicant Name (Printed): Abraham Perdomo

Applicant Signature:  Date: 05/15/2024

Witness Name (Printed): \_\_\_\_\_

Witness Signature: \_\_\_\_\_ Date: \_\_\_\_\_



614 Main St. Windermere, FL 34786  
Office: (407) 876-2563 Fax: (407) 876-0103

## PLUG INFORMATION





614 Main St. Windermere, FL 34786  
 Office: (407) 876-2563 Fax: (407) 876-0103



**Hubbell Non-NEMA Twist-Lock® Devices  
 50A, 250V DC/600V AC, 2 Pole, 3 Wire  
 Grounding Plug**

**Features**

- Super tough nylon housing offers better impact qualities.
- Stainless steel shroud protects contacts and prevents mis-mating.
- Heavy duty two-piece external cord clamp provides maximum strain relief.
- Box terminal with hex socket threaded slug, permits high clamping pressure on conductors without damaging strands.
- Thermoplastic polyester interior provides heat resistance and impact strength.

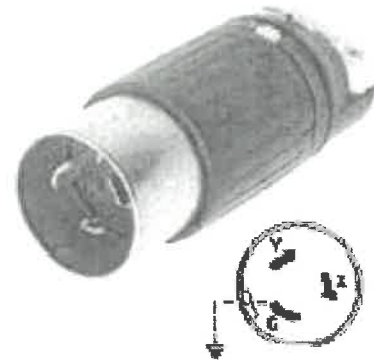

**Ordering Information**

Description	Cord Diameter	Hubbell Number
nylon housing thermoplastic polyester interior	.830" - 1.250" (21.1 - 31.8 mm)	HBL3753C

Stay Online Item # 4069

**Listings**

Listed to UL 499  
 Certified to CSA C22.2 No.42

**Specifications**

Housing	Nylon
Blade Holder	Polyester
Blades	Brass
Shell	Stainless Steel
Terminal Screws	Stainless Steel
Cord Grip	Polyester

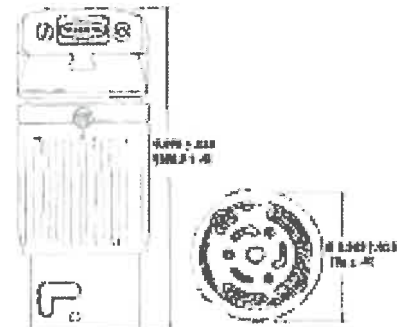

**Performance**

**Electrical**

Current Interrupting Certified for current interrupting at full rated current  
 Dielect Voltage Withstands 2,000V minimum

**Mechanical**

Terminal Accommodation #8 AWG - #4 AWG stranded copper wire only.

**Environmental**

Flammability HB or better per UL94/CSA 22.2 No.0,17  
 Operating Temperatures Maximum Continuous 75°C Minimum -40°C (w/o impact)



# MEAT ON FIREWOOD

## FOR 1 PERSON

1/2 Pound Beef Steak, 1/4 Poun pork belly, 1 pork ribs, 1 Sausage, cassava, pico de gallo, guasacaca (avocado sauce) and coleslaw salad **\$28**

## FOR 2 PERSONS

1 Pound Beef Steak, 1/2 Pound pork belly, 2 pork ribs, 1 Sausage, cassava, pico de gallo, guasacaca (avocado sauce) and coleslaw salad **\$50**

## FOR 4 PERSONS

2 Pound Beef Steak, 1 Pound pork belly, 4 pork ribs, 1 Sausage, cassava, pico de gallo, guasacaca (avocado sauce) and coleslaw salad **\$105**



## COMPANIONS



- Tequeños 5 units **\$10**
- French fries **\$5**
- Arepitas with Cream **\$9**
- Tostones or Maduros **\$8**

## DRINKS



- Coca Cola **\$3** Sprite **\$3**
- Fanta **\$3** Frescolite **\$4**
- Malta **\$4** Nestea **\$5**
- Papelon **\$5** Natural Juice **\$5**

## DOGS



- Special Dog Small \$6 Large \$10
- Regular sausage, bacon, chips, corn, onion, yellow cheese and sauces
- Polish Dog **\$12**
- Polish sausage, bacon, chips, corn, onion, yellow cheese and sauces
- Dog Chicken or Meat chicken or Meat \$14 Mixed \$16
- Chicken, Tenderloin, Picaña or Mixed, bacon, chips, corn, onion, yellow cheese and sauces

## BURGERS

(Add fried or hand cheese \$4)



- Acas Burger Single \$13 double \$16
- Meat, American cheese, bacon, caramelized onion and sauces
- Burger Chicken o Carne **\$16**
- Meat or chicken milanese, Munster cheese, ham, egg, bacon, chips, corn, onion and sauces
- Burger steak **\$20**
- Picaña, tenderloin or meat on stick, munster cheese, hand cheese, ham, egg, bacon, chips, corn, onion and sauces

## PETACONES

chicken or Meat \$20 Mixed \$22

Fried plantain, Chicken, Loin, Picaña or Mixed, lettuce, Ham, corn, Munster cheese, fried cheese and sauces



## AREPAS

- Arepa with Chicken and cheese **\$13**
- Arepa with Picaña and cheese **\$16**
- Arepa with Carne en Vara o Pork and cheese **\$16**
- Arepa Cabimera **\$20**

Picaña, Lomito, Chicken or mixed, lettuce, ham, hand cheese, fried cheese, parmesan and sauces



## CACHAPAS

- With cheese hand **\$14**
- With Cheese and Chicken **\$17**
- With Cheese and Picaña **\$20**
- With Cheese and Meat at **\$20**
- Rod or Pig



- Burger Chicken and Chop or Beef and Chop **\$20**

Chicken or meat Milanese, smoked chop, Munster cheese, hand cheese, ham, egg, bacon, chips, corn, onion and sauces



- Super Acas Burger **\$20**

Double meat or meat and chicken, Munster cheese, hand cheese, ham, egg, bacon, chips, corn, onion and sauces



- Powerful Burger **\$25**

Meat, Chicken Milanese, Chop, Munster cheese, fried cheese, ham, egg, slices, bacon, chips, corn, onion and sauces

















614 Main St. Windermere, FL 34786  
Office: (407) 876-2563 Fax: (407) 876-0103

## WINDERMERE FOOD TRUCK VENDOR APPLICATION

Owner Name: Amy Makarski Truck Name: Charm City Eats

Address: 19548 Whispering Brook Drive, Tampa FL 33647

Email: charmcityeatsfoodtruck@gmail.com Primary Phone: 443-845-1520

Thank you for your interest in the Town of Windermere Family Food Truck Events. The event is organized and owned by the Town of Windermere.

*Please read and review the rules and regulations for the event prior to completing this application.*

### PLEASE INITIAL EACH STATEMENT & SIGN

AM \$150 fee is due no later than one (1) week prior to each Windermere Food Truck event, and is payable by credit card (Visa, MasterCard, or Discover. American Express not accepted). Credit Card Authorization Forms can be obtained from Finance Clerk Theresa Syphers ([tsyphers@town.windermere.fl.us](mailto:tsyphers@town.windermere.fl.us)). The Town does not keep these forms on file. A new form will need to be submitted for each event. It is the sole responsibility of the vendor to provide accurate and current payment information; Windermere is not responsible for any overdraft or overage fees associated with the card on file. Late payments will result in additional fees, and too many will result in impact ability to participate in future events.

AM A copy of your Certificate of Liability Insurance with the Town of Windermere (614 Main Street, Windermere, FL 34786) listed as the Certificate Holder, Local Business Tax Receipt, and State of Florida Mobile Food Dispensing Vehicle License will be due upon approval.

AM Vendor is required to provide a trash can with a lid. Removal of trash and cleaning in your area is required, even if it is not yours.

AM Arrival time is 3:00pm. The set-up must wait until all trucks are in place. Trucks will be staged in designated areas prior to entering event space. Please do not arrive prior to 3:00pm; the weekly Farmers Market will be breaking down and early arrival will cause congestion and delays.





614 Main St. Windermere, FL 34786  
Office: (407) 876-2563 Fax: (407) 876-0103

AM Vendor is to provide their own power supply; either to connect to the Town's electrical supply or via quiet/silent generator. All power cords that are in the service area must be secured to the ground to avoid accidents per Florida State Law. Please ensure your cord is the appropriate length.

AM If a vendor wishes to connect to the Town's power, the vendor must identify the amount of amperage needed to run the Truck during the event. **Please review the attachment for the appropriate plug and amp size.** We also have a 20 amp that utilizes the standard 3 prong plug. It is the Vendor's responsibility to ensure they have the correct plug and to understand their own power needs. The Town will not be responsible for any damage caused by power.

AM Prior to 4:30pm: Should a Vendor arrive without the appropriate hookups, is unable to connect to the Town's power supply, they will be asked to leave the event. Should this occur after 4:30 pm, the Vendor will need to close their Truck and not allow service. They will not be allowed to remove their Truck until after the event has ended.

AM Service time will begin at either 5pm or 6pm depending on the month. Generally, the only month that will begin at 5pm is November. Town Staff will advise us of each month's start time. All events will run until 9:30pm.

AM Each truck should be prepared to serve approximately 250-300 people. Packing and cleaning up is permitted if you sell out prior to 9:30pm. Trucks must remain lit and accessible to optimize a professional look. The event ends at 9:30pm. It is the Vendor's responsibility to ensure they are not preparing/serving food or collecting payments after 9:30pm. Habitual disregard will affect ability to participate in future events.

AM Each vendor must collect 6.5% on all taxable sales.

AM The Town of Windermere reserves the right to alter scheduled dates, rotations, Truck participation, and Truck availability based on cuisine, amperage, and conduct of participants.

AM If a truck is scheduled for a Town of Windermere Food Truck Night event, and cannot attend for any reason, it is the Vendor's responsibility to find a suitable replacement. Ms. Lilian Colli will provide you with a contact list. When a replacement is found, the original Truck will call or email Ms. Lilian Colli at [lcolli@town.windermere.fl.us](mailto:lcolli@town.windermere.fl.us) or 407-876-2563 ext. 5327 for final approval. The replacement Truck must be cleared by Town Staff **AND** must be a Windermere-approved truck.

AM Replacement trucks are to pay the Town their \$150 fee directly. Replacement trucks should not make payments to the truck they are replacing. The Town will refund the replaced truck.



614 Main St. Windermere, FL 34786  
Office: (407) 876-2563 Fax: (407) 876-0103

AM If a truck is scheduled for a Windermere Food Truck Night Event, and fails to show up, or does not find a suitable replacement, that truck forfeits their \$150 fee to the Town of Windermere.

AM Each Truck is responsible for knowing and adhering to the rules set forth in this agreement. Parking is available on a first come-first serve basis. **NO PARKING IS ASSIGNED.**

AM Events are rain or shine. In the rare instance that an event is cancelled, the Town Manager will determine whether trucks will be refunded or not be charged for their next scheduled event.

AM Vendor shall indemnify and hold the Town of Windermere, its employees, agents, officials, and contractors, harmless from and against any and all claims, including, without limitation to, attorney's fees (whether incurred before during, or after trial, or upon appellate level) arising from the Vendor's participation in event.

The process after receiving an invite to a specific event date (**after being selected by the Selection Committee**) is as follows:

- Once your truck has been approved by the committee, Lilian Colli will contact you for any missing information such as liability insurance or business license.
- Truck Approval lists are updated monthly after each selection meeting. Town Staff will send out availability emails quarterly (December, March, June, and September).
- Schedules are created on a QUARTERLY basis (every three months). **Trucks can expect to be invited to an event zero to one event per quarter due to the high volume of trucks approved by the Town of Windermere Selection Committee.**

**I ACKNOWLEDGE THAT I HAVE READ AND UNDERSTAND THE TERMS AND CONDITIONS AS SET FORTH IN THIS APPLICATION TO PARTICIPATE IN WINDERMERE FOOD TRUCK EVENTS, AND I AGREE TO ALL STATEMENTS.**

Applicant Name (Printed): Amy Makarski

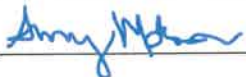
Applicant Signature:  Date: 7/22/24

Witness Name (Printed): \_\_\_\_\_

Witness Signature: \_\_\_\_\_ Date: \_\_\_\_\_

THE TOWN OF  
**Windermere**



614 Main St. Windermere, FL 34786  
 Office: (407) 876-2563 Fax: (407) 876-0103

**PLUG INFORMATION**





THE TOWN OF  
**Windermere**



614 Main St. Windermere, FL 34786  
Office: (407) 876-2563 Fax: (407) 876-0103



**Hubbell Non-NEMA Twist-Lock® Devices**  
50A, 250V DC/600V AC, 2 Pole, 3 Wire  
Grounding Plug

**Features**

- Super tough nylon housing offers better impact qualities.
- Stainless steel shroud protects contacts and prevents misrouting.
- Heavy duty two-piece external cord clamp provides maximum strain relief.
- Box terminal with hex socket threaded slug, permits high clamping pressure on conductors without damaging strands.
- Thermoplastic polyester interior provides heat resistance and impact strength.

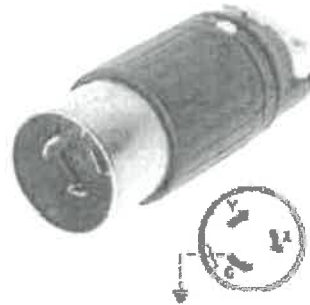

**Ordering Information**

Description	Cord Diameter	Hubbell Number
nylon housing, thermoplastic polyester interior	.830" - 1.250" (21.1 - 31.8 mm)	HBL3763C

Stay Online Item # 4069

**Listings**

Listed to UL 499  
Certified to CSA C22.2 No.42

**Specifications**

Housing	Nylon
Blade Holder	Polyester
Blades	Brass
Shell	Stainless Steel
Terminal Screws	Stainless Steel
Cord Grip	Polyester

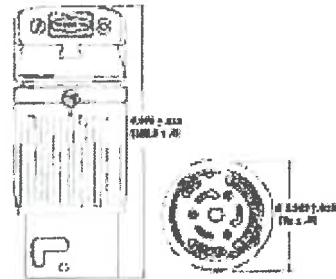

**Performance**

**Electrical**

Current Interrupting Dielect Voltage	Certified for current interrupting at full rated current Withstands 2,000V minimum
---	---

**Mechanical**

Terminal Accommodation	#8 AWG - #14 AWG stranded copper wire only.
------------------------	---

**Environmental**

Flammability	HB or better per UL94/CSA 22.2 No.0,17
Operating Temperatures	Maximum Continuous 75°C Minimum -40°C (w/o impact)

# CHARM CITY EATS

*menu*



## CHESAPEAKE JAMBALAYA

Shrimp, chicken, blue crab, andouille sausage, peppers, onions, tomatoes, rice \$ 15



## CRABBY FRIES

Blue crab dip smothered over old bay fries with peppers, drizzle BBQ sauce, jalapenos \$ 12



## DOUBLE DOWN FRIES

Blue crab dip smothered over old bay fries topped with 1 mini crab cake (\$ 15) or 2 mini crab cakes (\$ 22)

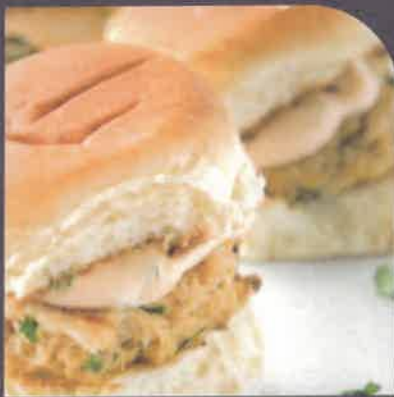

## CRAB CAKE SLIDERS

Two crab cake sliders with lettuce, tomato, b-more sauce \$ 12



## TRUFFLE CRAB MAC & CHEESE

Homemade mac, three cheese blend, fresh blue crab \$ 15



## COVER 2

Truffle crab mac smothered over old bay fries, topped with 1 mini crab cake (\$15) or 2 mini crab cakes (\$22)



# CHARM CITY EATS

## menu



### CHICKEN CHESAPEAKE

Pickle-brined fried chicken, lettuce, tomato, brioche bun, topped with crab dip \$ 13



### HOT CHICKEN

B-more Hot Chicken topped with coleslaw, old bay remoulade and jalapenos \$ 10



### CLASSIC CHICKEN

Pickle-brined fried chicken, lettuce, tomato, brioche bun. Chesapeake sauce \$ 10



### CHICKEN TENDERS

Three tenders & Old Bay Fries. Choice of dipping sauce \$ 12



### HOT TENDERS

Three HOT tenders & Old Bay Fries with Old Bay Remoulade \$ 13



### SSC TENDERS

Chicken tenders on top truffle crab mac & cheese, BBQ sauce, jalapenos \$ 16

### SIDES

OLD BAY FRIES \$ 3 / \$ 6  
COLESLAW \$ 3

















614 MAIN ST. WINDERMERE, FL 34786  
OFFICE: (407) 876-2563 FAX: (407) 876-0103

## WINDERMERE FOOD TRUCK VENDOR APPLICATION

Owner Name: Vanessa Lovato Truck Name: El Paladar Latino  
Address: 3571 Beau Rd, Kissimmee, FL, 34746  
Email: elpaladarlatinofood@gmail.com Primary Phone: 3213331518

Thank you for your interest in the Town of Windermere Family Food Truck Events. The event is organized and owned by the Town of Windermere.

*Please read and review the rules and regulations for the event prior to completing this application*

### PLEASE INITIAL EACH STATEMENT & SIGN

VL \$150 fee is due no later than one (1) week prior to each Windermere Food Truck event, and is payable by credit card (Visa, MasterCard, or Discover. American Express not accepted). Credit Card Authorization Forms can be obtained from Theresa Syphers ([tsyphers@town.windermere.fl.us](mailto:tsyphers@town.windermere.fl.us)). The Town does not keep these forms on file. A new form will need to be submitted each event. It is the sole responsibility of the vendor to provide accurate and current payment information; Windermere is not responsible for any overdraft or overage fees associated with the card on file. Late payments will result in additional fees, and too many will result impact ability to participate in future events.

VL A copy of your Certificate of Liability Insurance with the Town of Windermere (614 Main Street, Windermere, FL 34786) listed as the Certificate Holder, Local Business Tax Receipt, and State of Florida Mobile Food Dispensing Vehicle License will be due upon approval.

VL Vendor is required to provide a trash can with a lid. Removal of trash and clean up in your area is required; even if it is not yours.

VL Arrival time is 3:00pm. Set-up must wait until all trucks are in place. Trucks will stage in designated area prior to entering event space. Please do not arrive prior to 3:00pm; the weekly Farmers Market will be breaking down and early arrival will cause congestion and delays.



614 MAIN ST. WINDERMERE, FL 34786  
OFFICE: (407) 876-2563 FAX: (407) 876-0103

VL Vendor is to provide their own power supply; either to connect to the Town's electrical supply. No generators are permitted. All power cords that are in the service area must be secured to the ground to avoid accidents per Florida State Law. Please ensure your cord is the appropriate length.

VL If a vendor wishes to connect to the Town's power, the vendor must identify the amount of amperage needed to run the Truck during the event. Please review the attachment for the appropriate plug and amp size. We also have a 20 amp that utilizes the standard 3 prong plug. It is the Vendor's responsibility to ensure they have the correct plug and to understand their own power needs. The Town will not be responsible for any damages caused by power.

VL Prior to 4:30pm: Should a Vendor arrive without the appropriate hookups, is unable to connect to the Town's power supply, they will be asked to leave the event. Should this occur after 4:30pm, the Vendor will need to close down their Truck and not allow service. They will not be allowed to remove their Truck until after the event has ended.

VL Service time will begin at either 5pm or 6pm depending on the month. All events will run until 9:30pm.

VL Each truck should be prepared to serve approximately 250-300 people. Packing and cleaning up is permitted if you sell out prior to 9:30pm. Trucks must remain lit and accessible to optimize a professional look. The event ends at 9:30pm. It is the Vendor's responsibility to ensure they are not preparing/serving food or collecting payments after 9:30pm. Habitual disregard will affect ability to participate in future events.

VL Each vendor must collect 6.5% on all taxable sales.

VL The Town of Windermere reserves the right to alter scheduled dates, rotations, Truck participation, and Truck availability based on cuisine, amperage, and conduct of participants.

VL If a truck is scheduled for a Town of Windermere Food Truck Night event, and cannot attend for any reason, it is the Vendor's responsibility to find a suitable replacement. Theresa Syphers will provide you with a contact list. When a replacement is found, the original Truck will call or email Town Staff (Theresa Syphers [tsyphers@town.windermere.fl.us](mailto:tsyphers@town.windermere.fl.us) 407-876-2563 ext 5327) and Diane Edwards ([dedwards@town.windermere.fl.us](mailto:dedwards@town.windermere.fl.us) 407-876-2563 ext 5321) for final approval. The replacement Truck must be cleared by Town Staff, **AND** must be a Windermere-approved truck.

VL Replacement trucks are to pay the Town their \$150 fee directly. Replacement trucks should not make payments to the truck they are replacing. The Town will refund the replaced truck.



614 MAIN ST. WINDERMERE, FL 34786  
OFFICE: (407) 876-2563 FAX: (407) 876-0103

VL If a truck is scheduled for a Windermere Food Truck Night Event, and fails to show up, or does not find a suitable replacement, that truck forfeits their \$150 fee to the Town of Windermere.

VL Each Truck is responsible for knowing and adhering to the rules set forth in this agreement. Parking is available on a first come-first serve basis. **NO PARKING IS ASSIGNED.**

VL Events are rain or shine. In the rare instance that an event is cancelled, the Town Manager will determine whether trucks will be refunded or not be charged for their next scheduled event.

VL Vendor shall indemnify and hold the Town of Windermere, its employees, agents, officials, and contractors, harmless from and against any and all claims; including, without limitation to, attorney's fees (whether incurred before during, or after trial, or upon appellate level) arising from the Vendor's participation in event.

The process after receiving an invite to a specific event date (after being selected by the Selection Committee) is as follows: **texto**

- Once your truck has been approved by the committee, Diane Edwards will contact you for any missing information such as liability insurance or business license.
- Truck Approval lists are updated monthly after each selection meeting. Town Staff will send out availability emails quarterly (December, March, June, and September).
- Schedules are created on a QUARTERLY basis (every three months). **Trucks can expect to be invited to an event zero to one event per quarter due to the high volume of trucks approved by the Town of Windermere Selection Committee.**

**I ACKNOWLEDGE THAT I HAVE READ AND UNDERSTAND THE TERMS AND CONDITIONS AS SET FORTH IN THIS APPLICATION TO PARTICIPATE IN WINDERMERE FOOD TRUCK EVENTS, AND I AGREE TO ALL STATEMENTS.**

Applicant Name (Printed): Vanessa Lovato

Applicant Signature: 

Date: 12/20/22

Witness Name (Printed): Klieverth Cárdenas

Witness Signature: 

Date: 12/20/22



## PLUG INFORMATION





614 MAIN ST. WINDERMERE, FL 34786  
OFFICE: (407) 876-2563 FAX: (407) 876-0103



**Hubbell Non-NEMA Twist-Lock® Devices  
50A, 250V DC/600V AC, 2 Pole, 3 Wire  
Grounding Plug**

**Features**

- Super tough nylon housing offers better impact qualities.
- Stainless steel shroud protects contacts and prevents mismatching.
- Heavy duty two-piece external cord clamp provides maximum strain relief.
- Box terminal with hex socket threaded slug, permits high clamping pressure on conductors without damaging strands.
- Thermoplastic polyester interior provides heat resistance and impact strength.

**Ordering Information**

Description	Cord Diameter	Hubbell Number
nylon housing	.830" - 1.250"	HBL5763C
thermoplastic polyester interior	(21.1 - 31.8 mm)	

Stay Online Item # **4069**

**Listings**

Listed to UL 488  
Certified to CSA C22.2 No.42

**Specifications**

Housing	Nylon
Blade Holder	Polyester
Blades	Brass
Shell	Stainless Steel
Terminal Screws	Stainless Steel
Cord Grip	Polyester

**Performance**

**Electrical**

Current Interrupting Certified for current interrupting at full rated current  
Dielect Voltage Withstands 2,000V minimum

**Mechanical**

Terminal Accommodation #8 AWG - #14 AWG stranded copper wire only

**Environmental**

Flammability HB or better per UL94/CSA 22.2 No.0.17  
Operating Temperatures Maximum Continuous 75°C Minimum -40°C (w/o impact)

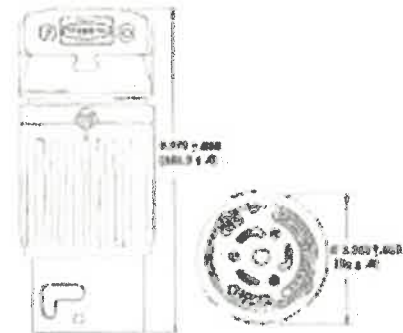

# STATE OF OHIO



OFFICE OF THE ATTORNEY GENERAL  
COLUMBUS, OHIO

STATE OF OHIO  
OFFICE OF THE ATTORNEY GENERAL  
COLUMBUS, OHIO

STATE OF OHIO  
OFFICE OF THE ATTORNEY GENERAL  
COLUMBUS, OHIO

STATE OF OHIO  
OFFICE OF THE ATTORNEY GENERAL  
COLUMBUS, OHIO

STATE OF OHIO  
OFFICE OF THE ATTORNEY GENERAL  
COLUMBUS, OHIO

STATE OF OHIO  
OFFICE OF THE ATTORNEY GENERAL  
COLUMBUS, OHIO

STATE OF OHIO  
OFFICE OF THE ATTORNEY GENERAL  
COLUMBUS, OHIO

STATE OF OHIO  
OFFICE OF THE ATTORNEY GENERAL  
COLUMBUS, OHIO

STATE OF OHIO  
OFFICE OF THE ATTORNEY GENERAL  
COLUMBUS, OHIO

STATE OF OHIO  
OFFICE OF THE ATTORNEY GENERAL  
COLUMBUS, OHIO

STATE OF OHIO  
OFFICE OF THE ATTORNEY GENERAL  
COLUMBUS, OHIO

STATE OF OHIO  
OFFICE OF THE ATTORNEY GENERAL  
COLUMBUS, OHIO

STATE OF OHIO  
OFFICE OF THE ATTORNEY GENERAL  
COLUMBUS, OHIO

STATE OF OHIO  
OFFICE OF THE ATTORNEY GENERAL  
COLUMBUS, OHIO

STATE OF OHIO  
OFFICE OF THE ATTORNEY GENERAL  
COLUMBUS, OHIO





Scanned with CamScanner





LUNCH • BREAKFAST • CATERING  
 SPECIAL EVENTS • CORPORATE  
 WEDDING • SCHOOL • PARTY  
 BRITHDAY • HOA • FAIR •



Permit ✓ License ✓ Insurance ✓ Liability ✓

☎ 321.333.1518

✉ elpaladarlatinofood@gmail.com

✳ Linktree.com/elpaladarlatino

📷 @elpaladarlatinofood

📘 El Paladar Latino

☰ elpaladarlatino.square.site



# HOUSE SPECIALS

## #1 LOADED AREPITAS

(FRIED) \$14.99

Four toasted arepitas with shredded chicken or pork, pico de gallo and house sauce.

Add: shredded yellow Cheese \$0.80



## #2 AREPA SANDWICH (FRIED)

Mozzarella cheese. \$9.99

+ Chicken \$10.99

+ Pork \$10.99

+ Beef \$11.99



## #3 EMPANADAS

Corn meal, stuffed with chicken or ground beef.

2 Pcs \$11.99

3 Pcs \$14.99



## #4 CACHAPAS

Venezuelan corn pancakes with cheese.

Venezuelan cheese \$11.99

+ Chicken \$13.99

+ Pork \$13.99

+ Beef \$14.99



## #5 PLANTAINS BASKETS

\$15.99

Four plantains baskets with (chicken or pork), pico de gallo and house sauce.



## #6 LOADED PLANTAINS (PATACON)

\$15.99

Fried plantain (pork or chicken), grilled peppers and onions, corn, shredded yellow cheese ketchup, house



# BURGERS

Accompanied with fries.

## #7 BACON CHEESE \$13.99

6oz 100% angus beef, brioche bun, chopped bacon, cheddar sauce (blasted cheese), ketchup, mustard.



## #8 PICO DE GALLO \$14.99

6oz 100% angus beef, brioche bun, pico de gallo, mozzarella cheese and special house sauce.



# HOT DOG

Accompanied with fries.

## #9 BACON CHEESE \$10.99

100% Premium all beef Nathan's, cheddar sauce, chopped bacon, ketchup.



## #10 PICO DE GALLO \$10.99

100% Premium all beef Nathan's, pico de gallo, corn, amber paladar sauce.

# KIDS

## #11 HOT DOG \$9.99

100% Premium all beef Nathan's, ketchup and french fries.

## #12 CHEESE BURGER \$10.99

100% angus beef, cheddar sauce, ketchup and french fries.

# FRIES

## #13 REGULAR \$4.49

## #14 SPECIAL FRIES \$6.99

Cheddar sauce, chopped bacon, green onion.

## #15 CRAZY FRIES (SALCHIPAPAS)

French fries, Nathan's Premium 100% beef sausage, corn, green onion, cheddar cheese, ketchup and special sauce.

Regular \$12.99

+ Chicken \$15.99

+ Pork \$15.99

+ Beef \$16.99





POLK COUNTY LOCAL BUSINESS TAX RECEIPT  
ACCOUNT NO. 255766 CLASS: B+ EXPIRES: 09/30/2024

OWNER NAME	LOCATION
VANESSA LOVATO	3571 BEAN RD KISSIMMEE

BUSINESS NAME AND MAILING ADDRESS	CODE	ACTIVITY TYPE
EL PALADAR LATINO FOODS LLC	720020	FOOD CATERING
VANESSA LOVATO	720040	FOOD EVENT VENDOR
3571 BEAN RD	720070	FOOD MOBILE VENDOR PREPARED FOOD
KISSIMMEE, FL 34746	720080	FOOD SERVICE
		PROFESSIONAL LICENSE (IF APPLICABLE)
		DBPR MFD6351185



OFFICE OF JOE G. TEDDER, CFC \* TAX COLLECTOR  
THIS POLK COUNTY LOCAL BUSINESS TAX RECEIPT MUST BE CONSPICUOUSLY DISPLAYED AT THE BUSINESS LOCATION

PAID - 1779276 10/09/2023 GBT TAX 57.75 EL PALADAR LATINO FOODS LLC

Scanned with CamScanner



## SEMINOLE COUNTY BUSINESS TAX RECEIPT

PO BOX 630, SANFORD, FL 32772 • 407-665-1000

WWW.SEMINOLECOUNTY.TAX

VALID THROUGH 09/30/24

**EL PALADAR LATINO FOODS LLC**

Account #: 218254

**VARIOUS LOCATIONS, FL 32714**

REGULATED

License # - MFD6351185

VANESSA LOVATO DE CARDENAS (AGENT)

Receipt #: 50202023101601038

Amount Paid: \$ 45.00

Date Paid: 10/16/2023

### **BUSINESS OWNER, PLEASE NOTE THE FOLLOWING:**

• **DISPLAY THE ABOVE RECEIPT PROMINENTLY:** This Business Tax Receipt shall be displayed conspicuously at the place of business in such a manner that it can be open to the view of the public and subject to inspection by all duly authorized officers of the County. Upon failure to do so the business shall be subject to the payment of another business tax for the same business or profession.

• **RENEW THIS TAX BEFORE IT EXPIRES:** Pursuant to Florida Statutes, all Business Tax Receipts shall be issued by the Tax Collector beginning July 1st of each year, and it shall expire on September 30th of the succeeding year. Those Business Tax Receipts issued as renewal accounts beginning October 1st shall be delinquent and subject to a delinquency penalty of 10% for the month of October, plus an additional 5% penalty for each month of delinquency thereafter until paid; provided that the total penalty shall not exceed 25% of the business tax for the delinquent establishment (Florida Statute [FS] 205.053 [1]).

A 25% penalty shall be imposed on any individual engaged in any new business or profession without first obtaining a Seminole County Business Tax receipt ([FS] 205.053 [2]).

This Business Tax Receipt is only a receipt for business taxes paid. It does not permit the taxpayer to violate any existing regulatory or zoning laws of the state, county, or municipality, nor does it exempt the taxpayer from any other required licenses, registrations, certifications, or permits. Business Tax requirements are subject to legislative change.

**REPORT ALL CHANGES:** The holder of this Business Tax Receipt is required to report a change in the following: Ownership, Business Location, Mailing Address, or any other information that would alter the status of the current year's information. This includes, but is not limited to, the loss of or a change in a State or Regulatory License which was used to qualify for the business identified on the current County Business Tax Receipt. If you have any changes to report, contact the Business Tax Department at 407-665-7636.

**EL PALADAR LATINO FOODS LLC  
3571 BEAU RD  
KISSIMMEE, FL 34746**

2023 - 2024



**Local Business Tax Receipt**

(Formerly known as "Business License" changed per state law HB1269-2006)

**Business Name**  
EL PALADAR LATINO FOODS LLC  
3571 BEAU RD  
KISSIMMEE, FL 34746

**Business Owner**  
EL PALADAR LATINO FOODS LLC

**Business Location**  
VARIOUS LOCATIONS  
ORLANDO, FL

NOTICE-THIS TAX RECEIPT ONLY EVIDENCES PAYMENT OF THE LOCAL BUSINESS TAX PURSUANT TO CH.205, FLORIDA STATUTES. IT DOES NOT PERMIT THE HOLDER TO OPERATE IN VIOLATION OF ANY CITY, STATE, OR FEDERAL LAW. CITY PERMITTING MUST BE NOTIFIED OF ANY MATERIAL CHANGE TO THE INFORMATION FOUND HEREIN BELOW. THIS RECEIPT DOES NOT CONSTITUTE AN ENDORSEMENT OR APPROVAL OF THE HOLDER'S SKILL OR COMPETENCY.

**Case Number:** BUS-1100655

**Issued Date:** 09/18/2023

**Expiration Date:** 09/30/2024

**Business type(s):**

Description	Year
PEDDLE 5965 FOOD PEDDLER .	2024



Local Business Tax Receipt  
City Hall, 400 South Orange Avenue, First Floor  
Post Office Box 4990  
Orlando, Florida 32802-4990

Phone: 407.246.2204 Fax: 407.246.3420

Email: [businesstax@orlando.gov](mailto:businesstax@orlando.gov)

Prompt! Interactive Voice Response System: 407.246.4444  
Visit our website: [orlando.gov/permits](http://orlando.gov/permits)



Local Business Tax Receipt is in addition to and not in lieu of any other tax required by law or municipal ordinance. Businesses are subject to regulation of zoning, health and other lawful authorities. This receipt is valid from October 1 through September 30 of receipt year. **Delinquent penalty is added October 1.**

1703 MOBILE FOOD TRUCK      2022      **EXPIRES**      9/30/2023      1703-1239697



LOVATO DE CARDENAS VANESSA  
 EL PALADAR LATINO FOODS LLC  
 LOVATO DE CARDENAS VANESSA  
 3571 BEAU RD  
 KISSIMMEE FL 34746

TOTAL TAX      \$15.00  
 PREVIOUSLY PAID      \$15.00  
 TOTAL DUE      \$0.00

MOBILE WORKING FROM OSCEOLA COUNTY  
 X - OUT OF COUNTY, 00000

PAID: \$15.00    2006-08950375    6/27/2023

This receipt is official when validated by the Tax Collector.

Orange County Code requires this local Business Tax Receipt to be displayed conspicuously at the place of business in public view. It is subject to inspection by all duly authorized officers of the County.

octaxcol.com | octaxcol

Powered with ComCommerce

The Town of  
**Windermere**



614 Main St. Windermere, FL 34786  
Office: (407) 876-2563 Fax: (407) 876-0103

## WINDERMERE FOOD TRUCK VENDOR APPLICATION

Owner Name: Laura Richards Truck Name: Fragaria Ice Cream

Address: 517 E Esther St. Olando, FL 32806

Email: fragariaicedream@gmail.com Primary Phone: 407-492-1535  
~~407-492-1535~~

Thank you for your interest in the Town of Windermere Family Food Truck Events. The event is organized and owned by the Town of Windermere.

*Please read and review the rules and regulations for the event prior to completing this application.*

### PLEASE INITIAL EACH STATEMENT & SIGN

LP \$150 fee is due no later than one (1) week prior to each Windermere Food Truck event, and is payable by credit card (Visa, MasterCard, or Discover. American Express not accepted). Credit Card Authorization Forms can be obtained from Finance Clerk Theresa Syphers ([tsyphers@town.windermere.fl.us](mailto:tsyphers@town.windermere.fl.us)). The Town does not keep these forms on file. A new form will need to be submitted for each event. It is the sole responsibility of the vendor to provide accurate and current payment information; Windermere is not responsible for any overdraft or overage fees associated with the card on file. Late payments will result in additional fees, and too many will result in impact ability to participate in future events.

LP A copy of your Certificate of Liability Insurance with the Town of Windermere (614 Main Street, Windermere, FL 34786) listed as the Certificate Holder, Local Business Tax Receipt, and State of Florida Mobile Food Dispensing Vehicle License will be due upon approval.

LP Vendor is required to provide a trash can with a lid. Removal of trash and cleaning in your area is required, even if it is not yours.

LP Arrival time is 3:00pm. The set-up must wait until all trucks are in place. Trucks will be staged in designated areas prior to entering event space. Please do not arrive prior to 3:00pm; the weekly Farmers Market will be breaking down and early arrival will cause congestion and delays.



614 Main St. Windermere, FL 34786  
Office: (407) 876-2563 Fax: (407) 876-0103

LP Vendor is to provide their own power supply; either to connect to the Town's electrical supply via quiet/silent generator. All power cords that are in the service area must be secured to the ground to avoid accidents per Florida State Law. Please ensure your cord is the appropriate length.

LP If a vendor wishes to connect to the Town's power, the vendor must identify the amount of amperage needed to run the Truck during the event. Please review the attachment for the appropriate plug and amp size. We also have a 20 amp that utilizes the standard 3 prong plug. It is the Vendor's responsibility to ensure they have the correct plug and to understand their own power needs. The Town will not be responsible for any damage caused by power.

LP Prior to 4:30pm: Should a Vendor arrive without the appropriate hookups, is unable to connect to the Town's power supply, they will be asked to leave the event. Should this occur after 4:30 pm, the Vendor will need to close their Truck and not allow service. They will not be allowed to remove their Truck until after the event has ended.

LP Service time will begin at either 5pm or 6pm depending on the month. Generally, the only month that will begin at 5pm is November. Town Staff will advise us of each month's start time. All events will run until 9:30pm.

LP Each truck should be prepared to serve approximately 250-300 people. Packing and cleaning up is permitted if you sell out prior to 9:30pm. Trucks must remain lit and accessible to optimize a professional look. The event ends at 9:30pm. It is the Vendor's responsibility to ensure they are not preparing/serving food or collecting payments after 9:30pm. Habitual disregard will affect ability to participate in future events.

LP Each vendor must collect 6.5% on all taxable sales.

LP The Town of Windermere reserves the right to alter scheduled dates, rotations, Truck participation, and Truck availability based on cuisine, amperage, and conduct of participants.

LP If a truck is scheduled for a Town of Windermere Food Truck Night event, and cannot attend for any reason, it is the Vendor's responsibility to find a suitable replacement. Ms. Lilian Colli will provide you with a contact list. When a replacement is found, the original Truck will call or email Ms. Lilian Colli at [lcolli@town.windermere.fl.us](mailto:lcolli@town.windermere.fl.us) or 407-876-2563 ext. 5327 for final approval. The replacement Truck must be cleared by Town Staff **AND** must be a Windermere-approved truck.

LP Replacement trucks are to pay the Town their \$150 fee directly. Replacement trucks should not make payments to the truck they are replacing. The Town will refund the replaced truck.





614 Main St. Windermere, FL 34786  
Office: (407) 876-2663 Fax: (407) 876-0103

LP If a truck is scheduled for a Windermere Food Truck Night Event, and fails to show up, or does not find a suitable replacement, that truck forfeits their \$150 fee to the Town of Windermere.

LP Each Truck is responsible for knowing and adhering to the rules set forth in this agreement. Parking is available on a first come-first serve basis. **NO PARKING IS ASSIGNED.**

LP Events are rain or shine. In the rare instance that an event is cancelled, the Town Manager will determine whether trucks will be refunded or not be charged for their next scheduled event.

LP Vendor shall indemnify and hold the Town of Windermere, its employees, agents, officials, and contractors, harmless from and against any and all claims, including, without limitation to, attorney's fees (whether incurred before during, or after trial, or upon appellate level) arising from the Vendor's participation in event.

The process after receiving an invite to a specific event date (after being selected by the Selection Committee) is as follows:

- Once your truck has been approved by the committee, Lilian Colli will contact you for any missing information such as liability insurance or business license.
- Truck Approval lists are updated monthly after each selection meeting. Town Staff will send out availability emails quarterly (December, March, June, and September).
- Schedules are created on a QUARTERLY basis (every three months). Trucks can expect to be invited to an event zero to one event per quarter due to the high volume of trucks approved by the Town of Windermere Selection Committee.

**I ACKNOWLEDGE THAT I HAVE READ AND UNDERSTAND THE TERMS AND CONDITIONS AS SET FORTH IN THIS APPLICATION TO PARTICIPATE IN WINDERMERE FOOD TRUCK EVENTS, AND I AGREE TO ALL STATEMENTS.**

Applicant Name (Printed): Laura Pichardo

Applicant Signature: *Laura Pichardo* Date: 7/2/24

Witness Name (Printed): ABEL ALVARADO

Witness Signature: *Abel Alvarado* Date: 7/2/24

# FRAGARIA

## NEW ZEALAND STYLE ICE CREAM

PREMIUM Plant-Based Vanilla Ice Cream Blended with REAL FRUIT.  
Build your Own Combination by Following these Steps:

**STEP 1:**  
Choose  
your SIZE

Kids / Small  
Cup  
\$6.25

Kids / Small  
Waffle Cone\*  
\$7.50

Regular  
Cup  
\$8.25

Regular  
Waffle Cone\*  
\$9.50

\*Gluten-Free and Plant-Based.



**STEP 2:**  
Choose your  
FRUIT

- Strawberry
- Mixed Berry
- Ltd. Time Fruit
- Cherry
- Blueberry

Craving  
Classic  
Vanilla?  
Just Ask.

**STEP 3:**  
Add TOPPINGS  
+\$1.00 Ea.

- Rainbow Sprinkles
- Chopped Pistachios
- Chopped Walnuts
- Oreo Pieces
- Tajin

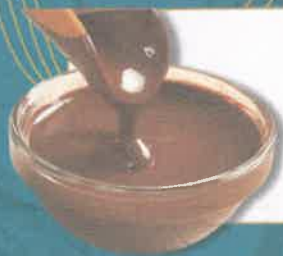

**STEP 4:**  
Add DRIZZLES  
+\$1.00 Ea.

- Semi-Sweet Melted Chocolate
- Chamoy (Sweet & Tangy Syrup)

ALLERGY NOTICE: Our ice cream contains coconut, cocoa butter, and cashews (tree nuts), with possible traces of other nuts. Fruit intermixing should be considered.













614 Main St. Windermere, FL 34786  
Office: (407) 876-2563 Fax: (407) 876-0103

## WINDERMERE FOOD TRUCK VENDOR APPLICATION

Owner Name: Caylee Gonzalez Truck Name: Let's Make It Saucy  
Address: 614 Obo Drive Davenport, FL 33896  
Email: makeitsaucy@yahoo.com Primary Phone: 585.797.5094

Thank you for your interest in the Town of Windermere Family Food Truck Events. The event is organized and owned by the Town of Windermere.

*Please read and review the rules and regulations for the event prior to completing this application*

### PLEASE INITIAL EACH STATEMENT & SIGN

CG \$150 fee is due no later than one (1) week prior to each Windermere Food Truck event, and is payable by credit card (Visa, MasterCard, or Discover. American Express not accepted). Credit Card Authorization Forms can be obtained from Finance Clerk Theresa Syphers ([tsyphers@town.windermere.fl.us](mailto:tsyphers@town.windermere.fl.us)). The Town does not keep these forms on file. A new form will need to be submitted each event. It is the sole responsibility of the vendor to provide accurate and current payment information; Windermere is not responsible for any overdraft or overage fees associated with the card on file. Late payments will result in additional fees, and too many will result impact ability to participate in future events.

CG A copy of your Certificate of Liability Insurance with the Town of Windermere (614 Main Street, Windermere, FL 34786) listed as the Certificate Holder, Local Business Tax Receipt, and State of Florida Mobile Food Dispensing Vehicle License will be due upon approval.

CG Vendor is required to provide a trash can with a lid. Removal of trash and clean up in your area is required; even if it is not yours.

CG Arrival time is 3:00pm. Set-up must wait until all trucks are in place. Trucks will stage in designated area prior to entering event space. Please do not arrive prior to 3:00pm; the weekly Farmers Market will be breaking down and early arrival will cause congestion and delays.





614 Main St. Windermere, FL 34786  
Office: (407) 876-2563 Fax: (407) 876-0103

CG Vendor is to provide their own power supply; either to connect to the Town's electrical supply via quiet/silent generator. All power cords that are in the service area must be secured to the ground to avoid accidents per Florida State Law. Please ensure your cord is the appropriate length.

CG If a vendor wishes to connect to the Town's power, the vendor must identify the amount of amperage needed to run the Truck during the event. **Please review the attachment for the appropriate plug and amp size.** We also have a 20 amp that utilizes the standard 3 prong plug. It is the Vendor's responsibility to ensure they have the correct plug and to understand their own power needs. The Town will not be responsible for any damages caused by power.

CG Prior to 4:30pm: Should a Vendor arrive without the appropriate hookups, is unable to connect to the Town's power supply, they will be asked to leave the event. Should this occur after 4:30 pm, the Vendor will need to close down their Truck and not allow service. They will not be allowed to remove their Truck until after the event has ended.

CG Service time will begin at either 5pm or 6pm depending on the month. Generally, the only month that will begin at 5pm is November. Town Staff will advise of each month's start time. All events will run until 9:30pm.

CG Each truck should be prepared to serve approximately 250 -300 people. Packing and cleaning up is permitted if you sell out prior to 9:30pm. Trucks must remain lit and accessible to optimize a professional look. The event ends at 9:30pm. It is the Vendor's responsibility to ensure they are not preparing/serving food or collecting payments after 9:30pm. Habitual disregard will affect ability to participate in future events.

CG Each vendor must collect 6.5% on all taxable sales.

CG The Town of Windermere reserves the right to alter scheduled dates, rotations, Truck participation, and Truck availability based on cuisine, amperage, and conduct of participants.

CG If a truck is scheduled for a Town of Windermere Food Truck Night event, and cannot attend for any reason, it is the Vendor's responsibility to find a suitable replacement. Ms. Brianna Wilson will provide you with a contact list. When a replacement is found, the original Truck will call or email Ms. Brianna Wilson at [BWilson@town.windermere.fl.us](mailto:BWilson@town.windermere.fl.us) or 407-876-2563 ext. 5321 for final approval. The replacement Truck must be cleared by Town Staff, **AND** must be a Windermere-approved truck.

CG Replacement trucks are to pay the Town their \$150 fee directly. Replacement trucks should not make payments to the truck they are replacing. The Town will refund the replaced truck.



614 Main St. Windermere, FL 34786  
Office: (407) 876-2563 Fax: (407) 876-0103

CG If a truck is scheduled for a Windermere Food Truck Night Event, and fails to show up, or does not find a suitable replacement, that truck forfeits their \$150 fee to the Town of Windermere.

CG Each Truck is responsible for knowing and adhering to the rules set forth in this agreement. Parking is available on a first come-first serve basis. **NO PARKING IS ASSIGNED.**

CG Events are rain or shine. In the rare instance that an event is cancelled, the Town Manager will determine whether trucks will be refunded or not be charged for their next scheduled event.

CG Vendor shall indemnify and hold the Town of Windermere, its employees, agents, officials, and contractors, harmless from and against any and all claims; including, without limitation to, attorney's fees (whether incurred before during, or after trial, or upon appellate level) arising from the Vendor's participation in event.

The process after receiving an invite to a specific event date (**after being selected by the Selection Committee**) is as follows:

- Once your truck has been approved by the committee, Brianna Wilson will contact you for any missing information such as liability insurance or business license.
- Truck Approval lists are updated monthly after each selection meeting. Town Staff will send out availability emails quarterly (December, March, June, and September).
- Schedules are created on a QUARTERLY basis (every three months). **Trucks can expect to be invited to an event zero to one event per quarter due to the high volume of trucks approved by the Town of Windermere Selection Committee.**

**I ACKNOWLEDGE THAT I HAVE READ AND UNDERSTAND THE TERMS AND CONDITIONS AS SET FORTH IN THIS APPLICATION TO PARTICIPATE IN WINDERMERE FOOD TRUCK EVENTS, AND I AGREE TO ALL STATEMENTS.**

Applicant Name (Printed): Caylee Gonzalez

Applicant Signature:  Date: 4/29/2024

Witness Name (Printed): \_\_\_\_\_

Witness Signature: \_\_\_\_\_ Date: \_\_\_\_\_



614 Main St. Windermere, FL 34786  
Office: (407) 876-2563 Fax: (407) 876-0103

## PLUG INFORMATION







614 Main St. Windermere, FL 34786  
Office: (407) 876-2563 Fax: (407) 876-0103



**Hubbell Non-NEMA Twist-Lock® Devices  
50A, 250V DC/600V AC, 2 Pole, 3 Wire  
Grounding Plug**

**Features**

- Super tough nylon housing offers better impact qualities.
- Stainless steel shroud protects contacts and prevents misstrafing.
- Heavy duty two-piece external cord clamp provides maximum strain relief.
- Box terminal with hex socket threaded slug, permits high clamping pressure on conductors without damaging strands.
- Thermoplastic polyester interior provides heat resistance and impact strength.

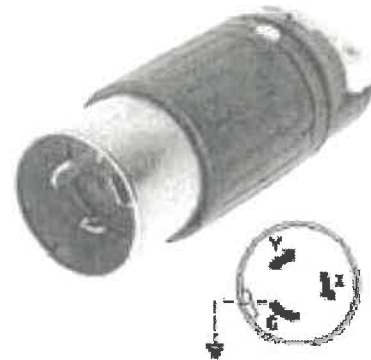

**Ordering Information**

Description	Cord Diameter	Hubbell Number
nylon housing thermoplastic polyester interior	.830" - 1.250" (21,1 - 31,8 mm)	HBL3763C

Stay Online Item # 4069

**Listings**

Listed to UL 488  
Certified to CSA C22.2 No.42

**Specifications**

Housing	Nylon
Blade Holder	Polyester
Blades	Brass
Shell	Stainless Steel
Terminal Screws	Stainless Steel
Cord Grip	Polyester

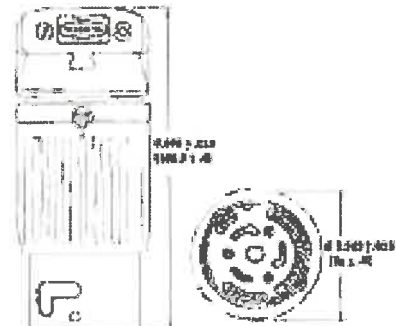

**Performance**

**Electrical**

Current Interrupting Certified for current interrupting at full rated current  
Dielect Voltage Withstands 2,000V minimum

**Mechanical**

Terminal Accommodation #8 AWG - #4 AWG stranded copper wire only.

**Environmental**

Flammability HB or better per UL94/CSA 22.2 No.0.17  
Operating Temperatures Maximum Continuous 75°C Minimum -40°C (two impact)

We were proudly voted Best of Florida in 2023 and are currently nominated again for 2024. Our menu changes based upon product availability and quality. Below is our current Sample Menu and pricing. All pricing is prior to sales tax.

## MENU

1. House Grilled Chicken Sandwich \$10.50
2. Grilled Chicken BLT Wrap \$12
3. Grilled Buffalo Chicken Wrap \$11
4. Tex Mex Chicken Tacos \$10.50
5. Steak Frita Cheesesteak- our signature dish - shaved ribeye marinated in our house marinade with grilled onions, cheese and potato sticks in a hoagie roll with side of cilantro crema (no changes/modifications) \$12
6. Triple Meat Wrap - includes steak, chicken & pork \$12
7. Fried Buffalo Shrimp Basket served with fries \$16
8. Mojo Pork Tacos \$10.50
9. Chefs Pork Sandwich \$10
10. Peruvian Fried Cod Tacos \$15

French Fries \$5.50

House Saucy Fries \$7.50

Fried Sweet Cheesecake Empanada \$6 ea

- Dulce de Leche
- Raspberry
- Guava
- Salted Caramel

Canned Soda/Bottled Water \$2







Peruvian Fried  
Cod Tacos



House Saucy Fries





Pan con Lechon  
(Chefs Pork Sandwich)





Steak Frita  
Cheesesteak



614 MAIN ST. WINDERMERE, FL 34786  
OFFICE: (407) 876-2563 FAX: (407) 876-0103

## WINDERMERE FOOD TRUCK VENDOR APPLICATION

Owner Name: Marcos Lucena Truck Name: PAC PIZZERIA  
Address: 8957 CAT PALM ROAD  
Email: PACPIZZERIA@GMAIL.COM Primary Phone: 4072236489

Thank you for your interest in the Town of Windermere Family Food Truck Events. The event is organized and owned by the Town of Windermere.

*Please read and review the rules and regulations for the event prior to completing this application*

### PLEASE INITIAL EACH STATEMENT & SIGN

ML \$150 fee is due no later than one (1) week prior to each Windermere Food Truck event, and is payable by credit card (Visa, MasterCard, or Discover. American Express not accepted). Credit Card Authorization Forms can be obtained from Finance Clerk Theresa Syphers ([tsyphers@town.windermere.fl.us](mailto:tsyphers@town.windermere.fl.us)). The Town does not keep these forms on file. A new form will need to be submitted each event. It is the sole responsibility of the vendor to provide accurate and current payment information; Windermere is not responsible for any overdraft or overage fees associated with the card on file. Late payments will result in additional fees, and too many will result impact ability to participate in future events.

ML A copy of your Certificate of Liability Insurance with the Town of Windermere (614 Main Street, Windermere, FL 34786) listed as the Certificate Holder, Local Business Tax Receipt, and State of Florida Mobile Food Dispensing Vehicle License will be due upon approval.

ML Vendor is required to provide a trash can with a lid. Removal of trash and clean up in your area is required; even if it is not yours.

ML Arrival time is 3:00pm. Set-up must wait until all trucks are in place. Trucks will stage in designated area prior to entering event space. Please do not arrive prior to 3:00pm; the weekly Farmers Market will be breaking down and early arrival will cause congestion and delays.





614 MAIN ST. WINDERMERE, FL 34786  
OFFICE: (407) 876-2563 FAX: (407) 876-0103

ML Vendor is to provide their own power supply; either to connect to the Town's electrical supply or via quiet/silent generator. All power cords that are in the service area must be secured to the ground to avoid accidents per Florida State Law. Please ensure your cord is the appropriate length.

ML If a vendor wishes to connect to the Town's power, the vendor must identify the amount of amperage needed to run the Truck during the event. Please review the attachment for the appropriate plug and amp size. We also have a 20 amp that utilizes the standard 3 prong plug. It is the Vendor's responsibility to ensure they have the correct plug and to understand their own power needs. The Town will not be responsible for any damages caused by power.

ML Prior to 4:30pm: Should a Vendor arrive without the appropriate hookups, is unable to connect to the Town's power supply, they will be asked to leave the event. Should this occur after 4:30pm, the Vendor will need to close down their Truck and not allow service. They will not be allowed to remove their Truck until after the event has ended.

ML Service time will begin at either 5pm or 6pm depending on the month. Generally, the only month that will begin at 5pm is November. Town Staff will advise of each month's start time. All events will run until 9:30pm.

ML Each truck should be prepared to serve approximately 250-300 people. Packing and cleaning up is permitted if you sell out prior to 9:30pm. Trucks must remain lit and accessible to optimize a professional look. The event ends at 9:30pm. It is the Vendor's responsibility to ensure they are not preparing/serving food or collecting payments after 9:30pm. Habitual disregard will affect ability to participate in future events.

ML Each vendor must collect 6.5% on all taxable sales.

ML The Town of Windermere reserves the right to alter scheduled dates, rotations, Truck participation, and Truck availability based on cuisine, amperage, and conduct of participants.

ML If a truck is scheduled for a Town of Windermere Food Truck Night event, and cannot attend for any reason, it is the Vendor's responsibility to find a suitable replacement. Diane Edwards will provide you with a contact list. When a replacement is found, the original Truck will call or email Diane Edwards ([dedwards@town.windermere.fl.us](mailto:dedwards@town.windermere.fl.us) 407-876-2563 ext 5321) for final approval. The replacement Truck must be cleared by Town Staff, **AND** must be a Windermere-approved truck.

ML Replacement trucks are to pay the Town their \$150 fee directly. Replacement trucks should not make payments to the truck they are replacing. The Town will refund the replaced truck.





614 MAIN ST. WINDERMERE, FL 34786  
OFFICE: (407) 876-2563 FAX: (407) 876-0103

ML If a truck is scheduled for a Windermere Food Truck Night Event, and fails to show up, or does not find a suitable replacement, that truck forfeits their \$150 fee to the Town of Windermere.

ML Each Truck is responsible for knowing and adhering to the rules set forth in this agreement. Parking is available on a first come-first serve basis. NO PARKING IS ASSIGNED.

ML Events are rain or shine. In the rare instance that an event is cancelled, the Town Manager will determine whether trucks will be refunded or not be charged for their next scheduled event.

ML Vendor shall indemnify and hold the Town of Windermere, its employees, agents, officials, and contractors, harmless from and against any and all claims; including, without limitation to, attorney's fees (whether incurred before during, or after trial, or upon appellate level) arising from the Vendor's participation in event.

The process after receiving an invite to a specific event date (after being selected by the Selection Committee) is as follows:

- Once your truck has been approved by the committee, Diane Edwards will contact you for any missing information such as liability insurance or business license.
- Truck Approval lists are updated monthly after each selection meeting. Town Staff will send out availability emails quarterly (December, March, June, and September).
- Schedules are created on a QUARTERLY basis (every three months). Trucks can expect to be invited to an event zero to one event per quarter due to the high volume of trucks approved by the Town of Windermere Selection Committee.

I ACKNOWLEDGE THAT I HAVE READ AND UNDERSTAND THE TERMS AND CONDITIONS AS SET FORTH IN THIS APPLICATION TO PARTICIPATE IN WINDERMERE FOOD TRUCK EVENTS, AND I AGREE TO ALL STATEMENTS.

Applicant Name (Printed): MARLOS LUENA

Applicant Signature: DAC PIZZERIA

Date: 01/03/24

Witness Name (Printed): MARLOS LUENA

Witness Signature: [Signature]

Date: 01/03/24

Ron DeSantis, Governor



Melanie S. Griffin, Secretary



**STATE OF FLORIDA  
DEPARTMENT OF BUSINESS AND PROFESSIONAL REGULATION**

**DIVISION OF HOTELS AND RESTAURANTS**

THE MOBILE FOOD DISP VEHICLE (2014) HEREIN IS LICENSED UNDER THE  
PROVISIONS OF CHAPTER 509, FLORIDA STATUTES  
VIN NUMBER: 7PNF3E327PC000151 SELF SUFFICIENT



**PAC PIZZERIA LLC**

PAC PIZZERIA  
45000 US HWY 27  
DAVENPORT FL 33897

**LICENSE NUMBER: MFD6351302**

**EXPIRATION DATE: FEBRUARY 1, 2025**

Always verify licenses online at [MyFloridaLicense.com](http://MyFloridaLicense.com)



ISSUED: 01/27/2024

Do not alter this document in any form.

This is your license. It is unlawful for anyone other than the licensee to use this document.







## Combos



### Picanha

Famous Brazilian  
steak with fries.  
Grilled, no spicy

**\$17,99**



### Chicken wings

Fried Regular wings

Fried, no spicy. 8pcs

**\$16,99**



### Chicken tenders

Delicious tenders  
with fries. 4pcs  
Fried, no spicy

**\$15.99**

**Sandwiche - \$13.99**



### Picanha

Sub bread, grilled  
Brazilian steak,  
mozzarella and  
parmesan

**Empanada - \$6.99**



**Cheese  
Chicken  
Beef**

## Beverage



Coke



Sprite



Coke Zero



Guaraná



[www.thepacpizzeria.com](http://www.thepacpizzeria.com)



[Pacpizzeria@gmail.com](mailto:Pacpizzeria@gmail.com)



**Pizzas 8" \$11.99**

**Pizza 12" \$16.99**



**Mozzarella**  
Tomato sauce, mozzarella and oregano



**Pepperoni**  
Tomato sauce, mozzarella, pepperoni, Parmesan and oregano



**Mushroom**  
Tomato sauce, mozzarella, mushroom, Parmesan and oregano



**Bacon**  
Tomato sauce, mozzarella, bacon and oregano



**Margherita**  
Tomato sauce, mozzarella, sliced tomato, basil and oregano

**Pizzas 8" \$14.99**

**Pizza 12" \$19.99**



**Meat Lovers**  
Tomato sauce, mozzarella, sausage, pepperoni, bacon, Parmesan and oregano



**Chicken Catupiry**  
Tomato sauce, Mozzarell, chicken, catupiry and oregano



**Delicious**  
Tomato sauce, mozzarell, Canadian bacon, bacon, catupiry, Parmesan and oregano



**Brazilian Sausage**  
Tomato sauce, mozzarell, Brazilian sausage, onions and oregano



**Franbacon**  
Tomato sauce, mozzarell, chicke, bacon, bbq sauce, catupir and oregano

**Appetizers**



**Chicken Brazilian Snack**  
5 Units - 10 Units

\$6.99 / \$12.99



**French Fries**  
200gr

\$5,99



**Cheese Brazilian Snack**  
5 Units - 10 Units

\$6.99 / \$12.99



**House French fries**  
With bacon, Parmesan

\$7,99



**Churros**  
With Dulce de Letche  
5 Units - 10 Units

\$6.99 / \$12.99



**Chicken wings**  
8 pcs

\$11,99





614 Main St. Windermere, FL 34786  
Office: (407) 876-2563 Fax: (407) 876-0103

## WINDERMERE FOOD TRUCK VENDOR APPLICATION

Owner Name: Randall Wiles Truck Name: Popcorn Fix  
Address: PO Box 700759, St. Cloud, FL 34770  
Email: randall@popcornfix.com Primary Phone: 407-536-7827

Thank you for your interest in the Town of Windermere Family Food Truck Events. The event is organized and owned by the Town of Windermere.

*Please read and review the rules and regulations for the event prior to completing this application.*

### PLEASE INITIAL EACH STATEMENT & SIGN

\$150 fee is due no later than one (1) week prior to each Windermere Food Truck event, and is payable by credit card (Visa, MasterCard, or Discover. American Express not accepted). Credit Card Authorization Forms can be obtained from Finance Clerk Theresa Syphers ([tsyphers@town.windermere.fl.us](mailto:tsyphers@town.windermere.fl.us)). The Town does not keep these forms on file. A new form will need to be submitted for each event. It is the sole responsibility of the vendor to provide accurate and current payment information; Windermere is not responsible for any overdraft or overage fees associated with the card on file. Late payments will result in additional fees, and too many will result in impact ability to participate in future events.

A copy of your Certificate of Liability Insurance with the Town of Windermere (614 Main Street, Windermere, FL 34786) listed as the Certificate Holder, Local Business Tax Receipt, and State of Florida Mobile Food Dispensing Vehicle License will be due upon approval.

Vendor is required to provide a trash can with a lid. Removal of trash and cleaning in your area is required, even if it is not yours.

Arrival time is 3:00pm. The set-up must wait until all trucks are in place. Trucks will be staged in designated areas prior to entering event space. Please do not arrive prior to 3:00pm; the weekly Farmers Market will be breaking down and early arrival will cause congestion and delays.







614 Main St. Windermere, FL 34786  
Office: (407) 876-2563 Fax: (407) 876-0103

 Vendor is to provide their own power supply; either to connect to the Town's electrical supplier via quiet/silent generator. All power cords that are in the service area must be secured to the ground to avoid accidents per Florida State Law. Please ensure your cord is the appropriate length.

 If a vendor wishes to connect to the Town's power, the vendor must identify the amount of amperage needed to run the Truck during the event. **Please review the attachment for the appropriate plug and amp size.** We also have a 20 amp that utilizes the standard 3 prong plug. It is the Vendor's responsibility to ensure they have the correct plug and to understand their own power needs. The Town will not be responsible for any damage caused by power.

 Prior to 4:30pm: Should a Vendor arrive without the appropriate hookups, is unable to connect to the Town's power supply, they will be asked to leave the event. Should this occur after 4:30 pm, the Vendor will need to close their Truck and not allow service. They will not be allowed to remove their Truck until after the event has ended.

 Service time will begin at either 5pm or 6pm depending on the month. Generally, the only month that will begin at 5pm is November. Town Staff will advise us of each month's start time. All events will run until 9:30pm.

 Each truck should be prepared to serve approximately 250-300 people. Packing and cleaning up is permitted if you sell out prior to 9:30pm. Trucks must remain lit and accessible to optimize a professional look. The event ends at 9:30pm. It is the Vendor's responsibility to ensure they are not preparing/serving food or collecting payments after 9:30pm. Habitual disregard will affect ability to participate in future events.

 Each vendor must collect 6.5% on all taxable sales.

 The Town of Windermere reserves the right to alter scheduled dates, rotations, Truck participation, and Truck availability based on cuisine, amperage, and conduct of participants.

 If a truck is scheduled for a Town of Windermere Food Truck Night event, and cannot attend for any reason, it is the Vendor's responsibility to find a suitable replacement. Ms. Lilian Colli will provide you with a contact list. When a replacement is found, the original Truck will call or email Ms. Lilian Colli at [lcolli@town.windermere.fl.us](mailto:lcolli@town.windermere.fl.us) or 407-876-2563 ext. 5327 for final approval. The replacement Truck must be cleared by Town Staff **AND** must be a Windermere-approved truck.

 Replacement trucks are to pay the Town their \$150 fee directly. Replacement trucks should not make payments to the truck they are replacing. The Town will refund the replaced truck.



614 Main St. Windermere, FL 34786  
Office: (407) 876-2563 Fax: (407) 876-0103

 If a truck is scheduled for a Windermere Food Truck Night Event, and fails to show up, or does not find a suitable replacement, that truck forfeits their \$150 fee to the Town of Windermere.

 Each Truck is responsible for knowing and adhering to the rules set forth in this agreement. Parking is available on a first come-first serve basis. **NO PARKING IS ASSIGNED.**

 Events are rain or shine. In the rare instance that an event is cancelled, the Town Manager will determine whether trucks will be refunded or not be charged for their next scheduled event.

 Vendor shall indemnify and hold the Town of Windermere, its employees, agents, officials, and contractors, harmless from and against any and all claims, including, without limitation to, attorney's fees (whether incurred before during, or after trial, or upon appellate level) arising from the Vendor's participation in event.

The process after receiving an invite to a specific event date (**after being selected by the Selection Committee**) is as follows:

- Once your truck has been approved by the committee, Lilian Colli will contact you for any missing information such as liability insurance or business license.
- Truck Approval lists are updated monthly after each selection meeting. Town Staff will send out availability emails quarterly (December, March, June, and September).
- Schedules are created on a QUARTERLY basis (every three months). **Trucks can expect to be invited to an event zero to one event per quarter due to the high volume of trucks approved by the Town of Windermere Selection Committee.**

**I ACKNOWLEDGE THAT I HAVE READ AND UNDERSTAND THE TERMS AND CONDITIONS AS SET FORTH IN THIS APPLICATION TO PARTICIPATE IN WINDERMERE FOOD TRUCK EVENTS, AND I AGREE TO ALL STATEMENTS.**

Applicant Name (Printed): Randall Wilson Sr

Applicant Signature:  Date: 8/5/2024

Witness Name (Printed): Victoria Wilson

Witness Signature:  Date: 8/5/2024







Florida Department of Agriculture and Consumer Services  
Division of Food Safety

**ANNUAL FOOD PERMIT**

Chapter 500, Florida Statutes  
Rule Chapter 5K-4.020 Florida Administrative Code  
(850) 245-5520 | www.FDACS.gov

**WILTON SIMPSON  
COMMISSIONER**

July 15, 2024

**PERMIT TYPE:** 164  
**PERMIT NUMBER:** 2025-N-2140262  
**FOOD ENTITY NUMBER:** 422300

**SRAK LLC**  
PO Box 700759,  
Saint Cloud, FL 34770-0759

**PERMITTED LOCATION ADDRESS:**  
Popcorn Fix  
4930 Cypress Hammock DR  
Saint Cloud, FL 34771-8923

**The attached permit will expire on July 14, 2025**

This annual food permit must be detached and shall be displayed in a conspicuous location at the permitted location. Failure to conspicuously display the permit may result in administrative action for violation of 5K - 4.020, F.A.C.

The renewal fee for all food permits shall be the same as the food permit fee required by subsection 5K-4.020(4), F.A.C., and shall be due annually on or before July 14. A late fee of \$100 will be imposed in accordance with Chapter 500, F.S., if the renewal fee for this food establishment is received by the Department after July 14. This fee is in addition to the food permit fee required by subsection 5K-4.020(4), F.A.C. It is the business owner's responsibility to ensure the accuracy of their account. Rule 5K-4.020(7), F.A.C., requires food establishments to notify the department within 30 days of closing. Updates to the owner contact information, email, and mailing addresses can be made at <https://foodpermit.fdacs.gov> or at (850) 245-5520.

**THIS FOOD PERMIT IS NOT TRANSFERABLE**

FDACS-14414 Rev. 08/23



Florida Department of Agriculture and Consumer Services  
Division of Food Safety

**2025**

**ANNUAL FOOD PERMIT**

Chapter 500, Florida Statutes  
Rule Chapter 5K-4.020 Florida Administrative Code  
(850) 245-5520 | www.FDACS.gov

**WILTON SIMPSON  
COMMISSIONER**

**PERMIT TYPE:** 164  
**FOOD ENTITY NUMBER:** 422300

**EXPIRATION DATE:** July 14, 2025

**LOCATION:**  
Popcorn Fix  
4930 Cypress Hammock DR  
Saint Cloud, FL 34771-8923

**OWNER:**  
SRAK LLC  
PO Box 700759,  
Saint Cloud, FL 34770-0759

This permit must be conspicuously displayed at the permitted location. Rule 5K-4.020(7), F.A.C., requires food establishments to notify the department within 30 days of closing.

**THIS FOOD PERMIT IS NOT TRANSFERABLE**

FDACS-14414 Rev. 08/23



Popcorn Fix <popcornfix4u@gmail.com>

## Mobile Vendor Food Permit Question

DHR, Info <Info.DHR@myfloridalicense.com>  
To: "savannah@popcornfix.com" <savannah@popcornfix.com>

Fri, Aug 2, 2024 at 8:31 AM

Good morning,

Thank you for contacting the Florida Department of Business & Professional Regulation, Division of Hotels and Restaurants. There are 3 main State agencies that license and regulated food services; our agency (DBPR); the Florida Department of Agriculture & Consumer Services (FDACS); and the Florida Department of Health. If you hold a license issued by FDACS, you do not need to obtain a DBPR food service license. Any food service license from the aforementioned agencies would be a "State license." If the City of Orlando disputes or has any questions, please ask them to contact us at [dhr.info@myfloridalicense.com](mailto:dhr.info@myfloridalicense.com).

Best regards,



**Michelle Keith**

Senior Management Analyst II

Division of Hotels and Restaurants

Florida Department of Business and Professional Regulation

[DHR.info@myfloridalicense.com](mailto:DHR.info@myfloridalicense.com)

[MyFloridaLicense.com](http://MyFloridaLicense.com)

The information contained in this transmission is intended solely for the use of the person(s) named herein. If you are not the intended recipient,

you are hereby notified that any review, dissemination, distribution or duplication of this communication is strictly prohibited. If you are not the

intended recipient, please contact me by reply e-mail and destroy all copies of the original message.

The State of Florida has a very broad public records law pursuant to Chapter 119, Florida Statutes. Most written communications to and from

state officials regarding state business are public records, available to the public and media upon request. Therefore, your e-mail communications

may be subject to public disclosure. [LARGER VIEW](#)



614 Main St. Windermere, FL 34786  
Office: (407) 876-2563 Fax: (407) 876-0103

## WINDERMERE FOOD TRUCK VENDOR APPLICATION

Owner Name: Vanessa Cardinale Truck Name: Son Pastelitos Fl  
Address: 2199 Garden Belle Dr. Clermont Fl. 34711  
Email: info@sonpastelitosfl.com Primary Phone: 407-9127188

Thank you for your interest in the Town of Windermere Family Food Truck Events. The event is organized and owned by the Town of Windermere.

*Please read and review the rules and regulations for the event prior to completing this application.*

### PLEASE INITIAL EACH STATEMENT & SIGN

VC \$150 fee is due no later than one (1) week prior to each Windermere Food Truck event, and is payable by credit card (Visa, MasterCard, or Discover. American Express not accepted). Credit Card Authorization Forms can be obtained from Finance Clerk Theresa Syphers ([tsyphers@town.windermere.fl.us](mailto:tsyphers@town.windermere.fl.us)). The Town does not keep these forms on file. A new form will need to be submitted for each event. It is the sole responsibility of the vendor to provide accurate and current payment information; Windermere is not responsible for any overdraft or overage fees associated with the card on file. Late payments will result in additional fees, and too many will result in impact ability to participate in future events.

VC A copy of your Certificate of Liability Insurance with the Town of Windermere (614 Main Street, Windermere, FL 34786) listed as the Certificate Holder, Local Business Tax Receipt, and State of Florida Mobile Food Dispensing Vehicle License will be due upon approval.

VC Vendor is required to provide a trash can with a lid. Removal of trash and cleaning in your area is required, even if it is not yours.

VC Arrival time is 3:00pm. The set-up must wait until all trucks are in place. Trucks will be staged in designated areas prior to entering event space. Please do not arrive prior to 3:00pm; the weekly Farmers Market will be breaking down and early arrival will cause congestion and delays.





614 Main St. Windermere, FL 34786  
Office: (407) 876-2563 Fax: (407) 876-0103

VC Vendor is to provide their own power supply; either to connect to the Town's electrical supply via quiet/silent generator. All power cords that are in the service area must be secured to the ground to avoid accidents per Florida State Law. Please ensure your cord is the appropriate length.

VC If a vendor wishes to connect to the Town's power, the vendor must identify the amount of amperage needed to run the Truck during the event. Please review the attachment for the appropriate plug and amp size. We also have a 20 amp that utilizes the standard 3 prong plug. It is the Vendor's responsibility to ensure they have the correct plug and to understand their own power needs. The Town will not be responsible for any damage caused by power.

VC Prior to 4:30pm: Should a Vendor arrive without the appropriate hookups, is unable to connect to the Town's power supply, they will be asked to leave the event. Should this occur after 4:30 pm, the Vendor will need to close their Truck and not allow service. They will not be allowed to remove their Truck until after the event has ended.

VC Service time will begin at either 5pm or 6pm depending on the month. Generally, the only month that will begin at 5pm is November. Town Staff will advise us of each month's start time. All events will run until 9:30pm.

VC Each truck should be prepared to serve approximately 250 -300 people. Packing and cleaning up is permitted if you sell out prior to 9:30pm. Trucks must remain lit and accessible to optimize a professional look. The event ends at 9:30pm. It is the Vendor's responsibility to ensure they are not preparing/serving food or collecting payments after 9:30pm. Habitual disregard will affect ability to participate in future events.

VC Each vendor must collect 6.5% on all taxable sales.

VC The Town of Windermere reserves the right to alter scheduled dates, rotations, Truck participation, and Truck availability based on cuisine, amperage, and conduct of participants.

VC If a truck is scheduled for a Town of Windermere Food Truck Night event, and cannot attend for any reason, it is the Vendor's responsibility to find a suitable replacement. Ms. Lilian Colli will provide you with a contact list. When a replacement is found, the original Truck will call or email Ms. Lilian Colli at [lcolli@town.windermere.fl.us](mailto:lcolli@town.windermere.fl.us) or 407-876-2563 ext. 5327 for final approval. The replacement Truck must be cleared by Town Staff **AND** must be a Windermere-approved truck.

VC Replacement trucks are to pay the Town their \$150 fee directly. Replacement trucks should not make payments to the truck they are replacing. The Town will refund the replaced truck.



614 Main St. Windermere, FL 34786  
Office: (407) 876-2563 Fax: (407) 876-0103

VC If a truck is scheduled for a Windermere Food Truck Night Event, and fails to show up, or does not find a suitable replacement, that truck forfeits their \$150 fee to the Town of Windermere.

VC Each Truck is responsible for knowing and adhering to the rules set forth in this agreement. Parking is available on a first come-first serve basis. **NO PARKING IS ASSIGNED.**

VC Events are rain or shine. In the rare instance that an event is cancelled, the Town Manager will determine whether trucks will be refunded or not be charged for their next scheduled event.

VC Vendor shall indemnify and hold the Town of Windermere, its employees, agents, officials, and contractors, harmless from and against any and all claims, including, without limitation to, attorney's fees (whether incurred before during, or after trial, or upon appellate level) arising from the Vendor's participation in event.

The process after receiving an invite to a specific event date (after being selected by the Selection Committee) is as follows:

- Once your truck has been approved by the committee, Lilian Colli will contact you for any missing information such as liability insurance or business license.
- Truck Approval lists are updated monthly after each selection meeting. Town Staff will send out availability emails quarterly (December, March, June, and September).
- Schedules are created on a QUARTERLY basis (every three months). **Trucks can expect to be invited to an event zero to one event per quarter due to the high volume of trucks approved by the Town of Windermere Selection Committee.**

**I ACKNOWLEDGE THAT I HAVE READ AND UNDERSTAND THE TERMS AND CONDITIONS AS SET FORTH IN THIS APPLICATION TO PARTICIPATE IN WINDERMERE FOOD TRUCK EVENTS, AND I AGREE TO ALL STATEMENTS.**

Applicant Name (Printed): Vanessa Cardinale

Applicant Signature: [Signature] Date: 05/25/24

Witness Name (Printed): \_\_\_\_\_

Witness Signature: \_\_\_\_\_ Date: \_\_\_\_\_

THE TOWN OF  
**Windermere**



614 Main St. Windermere, FL 34786  
Office: (407) 876-2563 Fax: (407) 876-0103

**PLUG INFORMATION**

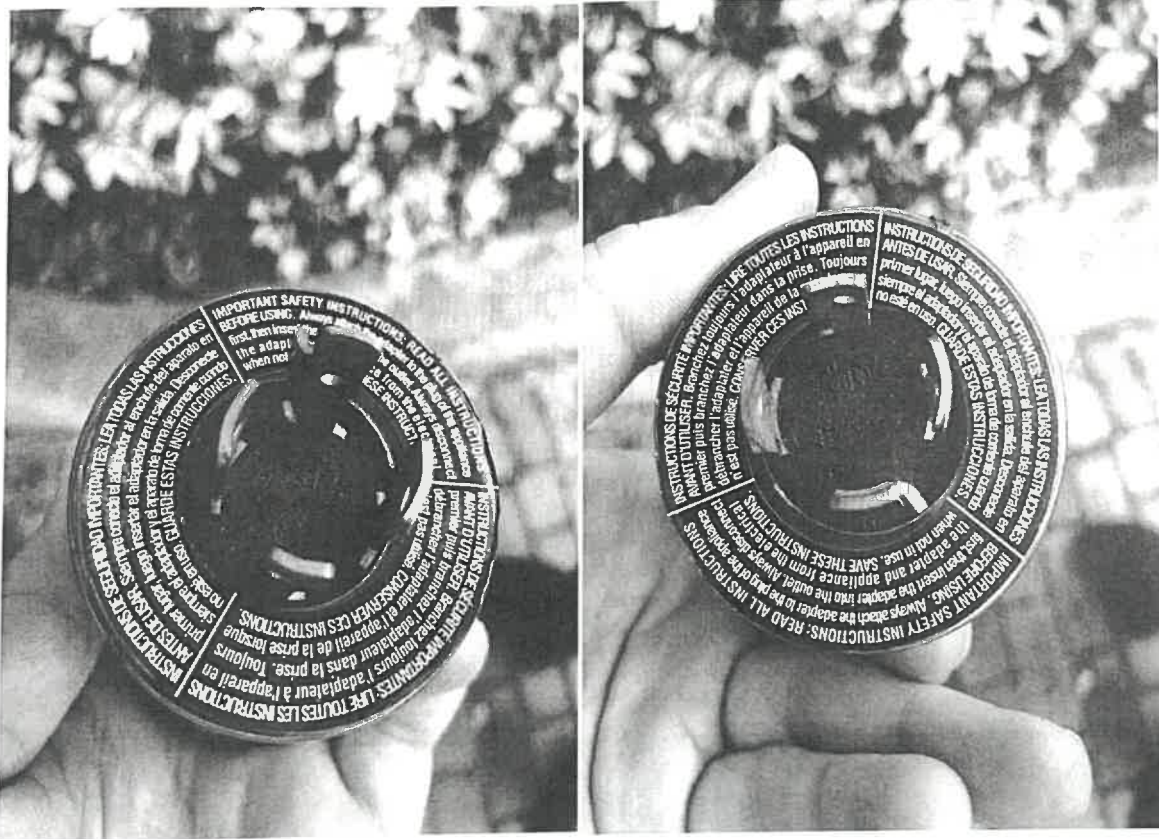



THE TOWN OF  
**Windermere**



614 Main St. Windermere, FL 34786  
Office: (407) 876-2563 Fax: (407) 876-0103



**Hubbell Non-NEMA Twist-Lock® Devices  
50A, 250V DC/600V AC, 2 Pole, 3 Wire  
Grounding Plug**

**Features**

- ◆ Super tough nylon housing offers better impact qualities.
- ◆ Stainless steel shroud protects contacts and prevents mismatching.
- ◆ Heavy duty two-piece external cord clamp provides maximum strain relief.
- ◆ Box terminal with hex socket threaded slug, permits high clamping pressure on conductors without damaging strands.
- ◆ Thermoplastic polyester interior provides heat resistance and impact strength.

**Ordering Information**

Description	Cord Diameter	Hubbell Number
nylon housing, thermoplastic polyester interior	.830" - 1.250" (21.1 - 31.8 mm)	HBL3763C

Stay Online Item # **4069**

**Listings**

Listed to UL 498  
Certified to CSA C22.7 No.42

**Specifications**

Housing	Nylon
Blade Holder	Polyester
Blades	Brass
Shell	Stainless Steel
Terminal Screws	Stainless Steel
Cord Grip	Polyester

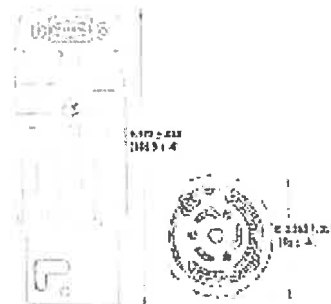

**Performance**

**Electrical**

Current Interrupting	Certified for current interrupting at full rated current
Dielect Voltage	Withstands 2,000V minimum

**Mechanical**

Terminal Accommodation	#8 AWG - #4 AWG stranded copper wire only
------------------------	---

**Environmental**

Flammability	HB or better per UL94/CSA 22.2 No.C.17
Operating Temperatures	Maximum Continuous 75°C Minimum -40°C (w/o impact)

# OUR Menu

PASTELITOS

\$3.50 ea

- 1 Cheese
- 2 Mashed potatoes with cheese
- 3 Guava cheese
- 4 Leek with cream cheese
- 5 Ham and cream cheese
- 6 Ham and cheese
- 7 Bacon, corn and mozzarella
- 8 Mushrooms with mozzarella
- 9 Chistorra with mozzarella
- 10 Pizza
- 11 Hawaiian
- 12 Vegan
- 13 Chicken
- 14 Ground beef
- 15 Ground beef with rice
- 16 Shredded beef
- 17 Shredded beef with cheese
- 18 Shrimp
- 19 Crab with cream cheese
- 20 Reese's
- 21 Sweet plantain and cheese
- 22 Al pastor
- 23 Ricotta and spinach

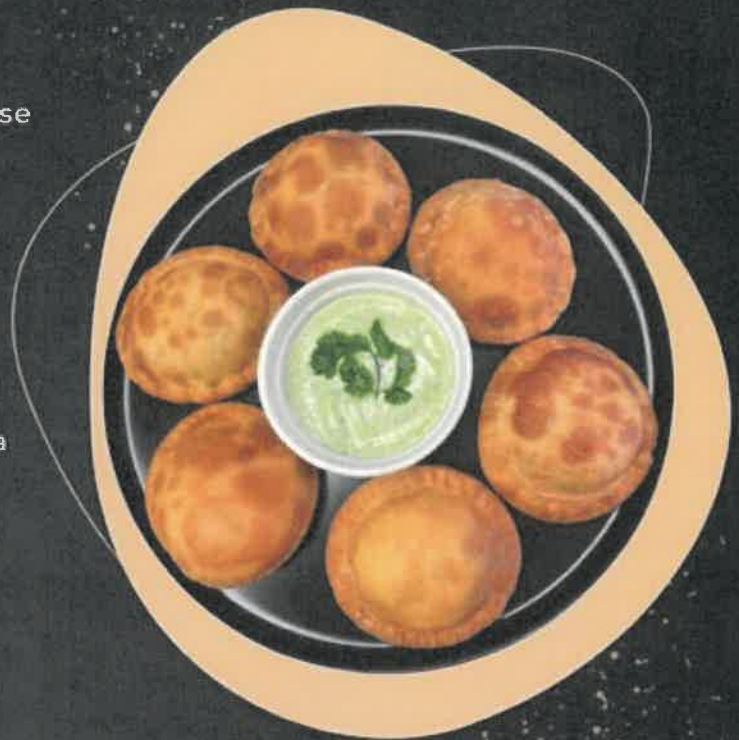

## DRINKS

- Maltin Polar
- Natural Juice
- Soda

## TEQUEÑOS

Tequeños 6 unit.

\$10



@sonpastelitos\_fl









# Town of Windermere Food Truck Nights



## 2024/2025 Sponsorship Opportunities

Windermere hosts monthly Food Truck events September through May each year. Events are generally held the 4<sup>th</sup> Friday of the month from 5:30pm – 9:30pm.\* Attendance ranges from 1,200 to 4,000 and includes locals and visitors from across West Orange County.  
(Events are not held the months of June, July, or August)

### Sponsorship Opportunities Contact:

**Lilian Colli, Administrative Assistant**

[lcolli@town.windermere.fl.us](mailto:lcolli@town.windermere.fl.us) / 407-876-2563 ext. 5327

\*November/December may be held the 3<sup>rd</sup> Friday of the month.

November & September may also begin at 5pm.

Town Staff will confirm dates/times at the time of signing.

### Diamond Sponsor - \$2,500

Annual sponsorship opportunity; 2 available per year

- ❖ Booth (up to 20x20) at every regular Food Truck Event (9) for a 12-month period
- ❖ Business logo/name included and linked on all applicable Windermere Food Truck Night platforms:
  - Social Media (Facebook, Instagram)
  - Town of Windermere website
  - Flyers
  - Banners
  - Quarterly publication, *Windermere Gazette*
  - Band, DJ, and/or MC will announce sponsorship during event

### Platinum Sponsor - \$1,000

3-month sponsorship opportunity; 2 available January – March and October – December. Not available May or September

- ❖ Booth (up to 10x10) at every Food Truck Event for one quarter
- ❖ Business logo/name included and linked on all applicable Windermere Food Truck Night platforms:
  - Social Media (Facebook, Instagram)
  - Town of Windermere website
  - Flyers
  - Quarterly publication, *Windermere Gazette*
  - Band, DJ, and/or MC will announce sponsorship during event

### Gold Sponsor - \$750

1-month sponsorship opportunity; 2 available **September – December**. We tend to have higher crowds during these months:

- **September** – *National Night Out* recognizing law enforcement and first responders. Various agencies are present with kids' activities. 2022 event saw approximately 3,000 attendees.
- **November** – *Light Up Windermere*. Biggest event of the year, 2022 event saw approximately 4,000 attendees. *May be held the 3<sup>rd</sup> Friday and have an earlier start time. Town Staff will confirm at time of signing.*
- ❖ Booth (up to 10x10) at one Food Truck Event during the months of September - December
- ❖ Business logo/name included and linked on all applicable Windermere Food Truck Night platforms:
  - Social Media (Facebook, Instagram)



- Town of Windermere website
- Flyers
- Quarterly publication, *Windermere Gazette*
- Band, DJ, and/or MC will announce sponsorship during event

**Silver Sponsor - \$500**

1-month sponsorship opportunity; 1-3 available October, December – May. **Not available September or November.**

- ❖ Booth (up to 10x10) at one Food Truck Event during the months of January - August
- ❖ Business logo/name included and linked on all applicable Windermere Food Truck Night platforms:
  - Social Media (Facebook, Instagram)
  - Town of Windermere website
  - Flyers
  - Band, DJ, and/or MC will announce sponsorship during event

**Community partner - \$250 OR DONATE a Pre-Approved Youth Activity\***

1-month sponsorship opportunity; 1 available October, December – May. Not available September or November.

- ❖ Booth (up to 10x10) at one Food Truck Event

*\*Examples of Pre-Approved Youth Activities: Face-Painting, Ballon Making, Popular Characters (so kids can take pictures with), Popcorn and/or Cotton-Candy Machine, Fair Games.*

## Sponsorship Agreement

**Business Name:** \_\_\_\_\_

**Sponsorship Level:** \_\_\_\_\_ **Month(s) Requested:** \_\_\_\_\_

Diamond \$2,500  
 Platinum \$1,000  
 Gold \$750  
 Silver \$500  
 Community Partner \$250 or Youth Activity

**Website:** \_\_\_\_\_

**Social Media Handles**  
**Facebook:** \_\_\_\_\_ **Instagram:** \_\_\_\_\_

**Contact Name:** \_\_\_\_\_

**Contact Phone:** \_\_\_\_\_ **Contact email:** \_\_\_\_\_

Please initial each statement below

\_\_\_\_\_ Payment and agreement will be due one month prior to event date(s) requested.

\_\_\_\_\_ Please make checks payable to the Town of Windermere. Mail or deliver to:

Town of Windermere  
ATTN: Lilian Colli  
614 Main Street  
Windermere, FL 34786

\_\_\_\_\_ Please email a JPEG, PDF, or PNG version of your logo to Lilian Colli one month prior to the event date(s) requested: [colli@town.windermere.fl.us](mailto:colli@town.windermere.fl.us)

\_\_\_\_\_ The Town of Windermere reserves the right to cancel events up until and including the day of the event for any reason.

\_\_\_\_\_ In the event that the Town of Windermere cancels an event, sponsorship dates will be rescheduled in lieu of a refund.

\_\_\_\_\_ The Town of Windermere makes no guarantee of crowd attendance.

\_\_\_\_\_ The Town of Windermere is not responsible for any loss or damage incurred while attending Food Truck Night events.

\_\_\_\_\_ Events will begin at either 5:00pm or 5:30pm. The Town will advise of a particular month's start time. Set up should be complete 30 minutes prior to event start. Load-in might begin at 2:30pm.

\_\_\_\_\_ Events end at 9:30pm. Tear down should be complete by 10:00pm.

\_\_\_\_\_ Sponsor will provide their own tent and decorations. Sponsor will advise if/how many tables and chairs are needed, and the Town will provide.

\_\_\_\_\_ The Town will take reasonable steps to reserve at least 1 parking spot per sponsor; however, the Town cannot guarantee the location of the parking spots.

**I have read, understand, and agree to the information provided  
in this agreement, as well as the statements above:**

**Sponsor Signature:** \_\_\_\_\_ **Date:** \_\_\_\_\_

**Staff Signature:** \_\_\_\_\_ **Date:** \_\_\_\_\_

**Type of Payment:** \_\_\_\_\_ **Amount:** \$ \_\_\_\_\_ **Date Paid:** \_\_\_\_\_



THE TOWN OF

Windermere



# CALLING ALL PARENTS TO KIDS BACK TO SCHOOL CELEBRATION!

## Sponsors



**SATURDAY, AUGUST 10TH**

FROM 5:00 TO 9:30 PM

TOWN SQUARE PARK

## Featuring Trucks

- Al's Gelato Dessert Sundaes - The Pretzel Spot
- Bowls For Tu - K & E Catering - Brazilian Passion
- Chicken Waffle Gril - Churros & Cream
- El Cubanito Subs - Eat-N-Wash: The Lunchbox - La Palette
- The Crepe Company - OVN Pizza - The Rancho Express
- Orlando Snow Kone Factory - Pho Wheels Orlando
- Schnitz and Giggles - Smoking Soul BBQ

## Special Participation



WINDERMERE  
**BREWING**

COMPANY

ESTD 2016

117

