



WINDERMERE PARKS & RECREATION COMMITTEE
November 16, 2020 AGENDA

In order to maintain a 1hour time schedule, the committee will address the monthly agenda items only unless time remains for New Business discussion at the end. Agenda items should always be submitted in advance for committee consideration.

1. OPEN FORUM/PUBLIC COMMENT (3 Minute Limit):
2. OLD BUSINESS:
 - a. Events:
 - i. Windermere Pet Fest Sat. March 7, 2020
 1. Create subcommittee for next year's event – On hold pending covid
 - ii. 19th Annual UMC Run Among the Lakes
 1. Move 2021 race to October, 2021
 2. Orlando Health in talks to become new title sponsor – 2 year contract with 2 year option
 3. Give away remaining shirts & medals to residents
 - iii. Halloween Costume Parade and Hayride Saturday, October 31, 2020 (Doug)
 1. Great event – really good turnout
 2. Report from Doug
 - b. Tennis
 - i. Tennis Report – Doug
 - c. Parks
 - i. CIP
 1. Fernwood Park –
 - Discuss improvements and concerns of neighbors - attached
 - Comments from Frank in minutes
 -
 2. Central Park
 - Review and approve proposal to add handicapped swing and access - \$10,465.00 see attached
 - Landscaping plan – attached – too many bushes?
 - Tree plan from Tree Board
 3. Frank – kayak storage at parks
 - Boathouses?
 - ii. Review & modify final plans from IDG for Lake Bessie & Lake Down pathways -
 1. Tabled for near future

Park Walk Through 20191019

Fernwood

1. Add berms/swales at end of roadway near lake
2. Add large oak tree in center of roundabout
3. Add border to roundabout so people don't park there
4. Add hedge along chain link fence (west side)
5. Consider adding gravel in circle driveway area

3. NEW BUSINESS

a. MINUTES

- i. Approval October Meeting Minutes (Attached-Committee Option)

- b. Proposal from John Nabers about donating statue for display in Central Park – photo attached

c. Liaison Reports

- i. Councilman McKinley
- ii. Robert Smith
- iii. Scott Brown

4. NEXT MEETING DATE – Thursday December 10, 2020

5. ADJOURNMENT

JAMES L. CLARK, scv, CIC
P.O. Box 885 Windermere, Florida 34786
407/ 876-2755 jclark31@cfl.rr.com

30 year Member of Florida Association of Environmental Professionals
44 Year Member of the International Real Estate Institute

November 4, 2020

Mrs. Nora Brophy, Chairman, Town of Windermere Parks Committee

Re: Proposal to add a 352-foot walkway and Gazebo at Fernwood Park

In 1999 I permitted and currently manage the TM-Econ Mitigation Bank, an eight square mile wetlands bank that is largest wetland mitigation bank in Central Florida. With this project I have gained considerable knowledge of how wetlands function and how they are regulated in order to maintain the value that wetlands provide to the environment of our State.

As a brief review of history, during the early 1970's the Town wisely decided to close the street ends along the eastern shore of Lake Butler so that they did not become an attractant to nonresident users, thus avoiding the problems associated with uncontrolled use of such public spaces. This action also preserved considerable stretches of the ecotone that have since been managed well by the property owners adjacent to those street ends and taking this decision has been beneficial to the Town.

During the late 1980's the increased public use of Bird Island as a recreational anchorage has caused significant harm to the avian population of this island by boaters who intrude into this sanctuary, create unremoved waste both onshore and into the water column. Additional harm is caused by extremely loud music from these visitors during the warm months that has severely reduced the population of Egrets and Osprey who now cling to the south shore of the island instead of nesting along the north eastern banks of this once valuable bird sanctuary. Then there is the significant disregard of the current rules requiring much additional policing efforts required to mitigate these impacts.

Your proposal to significantly impact the few remaining areas of natural shoreline ecotone along Lake Butler by constructing an elevated walkway and a gazebo will certainly degrade the functionality of this wetland and cause new problems for the Town.

Beyond the initial cost of construction of this significantly large public walkway will be the cost of maintaining it to insure the safety of the users and the ongoing maintenance itself will continue to cause periodic impacts to the adjacent wetland with the need to periodically access this structure.

The history of Bird Island tells us that public use of the proposed facility will require policing of the users. Best ask the Windermere Police if they have the manpower to patrol another facility that will require their significant attention. The potential for abuse of a land-based facility such as this will be much greater than what we experience on the island which requires boat access.

Currently, parking space at Fernwood on weekends is already near or at capacity. Where will the visitors park who take in the sights or activities at a new boardwalk and gazebo? The planned expansion of the retention pond on the north side of the boat ramp is already expected to further impact the existing parking capacity.

The environmental permitting of this facility will be much more difficult due to the designation of Lake Butler as an Outstanding Florida Waters. This will require the Town to convince the State that this planned project is "clearly in the public interests". We would need to convince the FDEP that this facility is a "public necessity" and one that must be constructed at this specific location. If it has not already been done, I suggest that before spending any real money on design and permitting, a meeting with the FDEP should be held to determine their opinion of the chances of this project surmounting these statutory obstacles.

Finally, a significant increase in traffic and noise of such a public facility, surrounded by existing homes, should be taken into consideration by your committee and the Town Council. Ask yourself, if you lived next door to the proposed facility whether you would encourage its construction?

As more of our residents own watercraft, we will continue to experience the inevitable increase of traffic on Butler St. between 6th and 7th Ave. Property owners along the east shore of Lake Butler are already being impacted by the noise and pollution of the lake by public use of Bird Island.

One needs to ask whether the Town really needs the proposed public facility and whether it will be worth the cost, additional traffic, noise, additional policing and disruption to our neighborhood needed to pay for its creation? In My opinion, it is not, and this wetland should be returned to its natural condition and kept that way.

Respectfully,

A handwritten signature in cursive script, appearing to read "James R. Clark".

Jim Clark

Our names are Bill and Terry Osborne, and for the last 19 years, we have lived at 220 West 7th Avenue, which is two houses from Fernwood Park on Lake Butler. Prior to that, we lived around the corner at 105 8th Avenue for 15 years.

We are opposed to the proposed Fernwood Park boardwalk for several reasons.

- 1 1. Fernwood Park is the only boat ramp exclusively for town residents, and over the 34 years we've lived near it, we have seen the boat and park traffic dramatically increase as the town has annexed hundreds of homes. It's a busy boat ramp with minimal parking. As West 7th Avenue residents, we are already faced with heavy boat/trailer traffic and a street that is increasingly becoming overflow parking for Fernwood Park. The additional amenity of the proposed boardwalk will exacerbate the problem.
2. The addition of a boardwalk will lure more non-residents to the park as they travel to and from Bird Island. As it is, the Town hasn't been able to manage the large numbers of non-resident boaters being picked up and dropped off at Fernwood Park nor the related, rowdy partiers who congregate in the park. The proposed boardwalk will aggravate the current situation.
3. We are concerned about the boardwalk's environmental impact on the wetlands, which have already been compromised by some of the tree and vegetation clearing that has occurred.

We appreciate the dedicated work of the Parks and Recreation Committee to enhance residents' enjoyment of our beautiful town and its unique environment. We believe that interested residents should have the opportunity to enjoy the lakes. However, we oppose the proposed Fernwood Park boardwalk plan for the increased stress on the park, roads and Bird Island that will result from it.

Respectfully,
Bill Osborne, Windermere Town Council 1996-2002; Windermere Mayor 2002-2004
Terry Osborne

I live in Windermere near the elementary school on Bayshore Drive. My children and I are on the chain of lakes regularly. I wish to voice my opposition to the proposed Boardwalk at Fernwood Park and encroaching onto Lake Butler. Frankly, this is a terrible idea.

Fernwood Park is small town park that can barely accommodate the ramp and park visitation.

The addition of the proposed boardwalk will be a huge disservice to the residents of Windermere. We already have problems with Bird Island and this will only make the situation worse.

As the past chairman of the South Florida Water Management District, I understand the potential environmental impacts to the wetlands and outstanding Florida water quality of Lake Butler. I urge you to solicit the Mayor and Town Council members to VOTE NO to the proposed Boardwalk at Fernwood Park.

Thank you,

Dan O'Keefe
11068 Bayshore Drive
Windermere

Good Evening Nora,

As Windermere town residents, my husband and I would like to express our opposition to the proposed boardwalk construction at Fernwood Park.

This park has served as a boat ramp for many years and already sees lots of vehicle traffic. Our fear is that the addition of the boardwalk will only increase the amount of traffic to that small area. Not to mention there is limited parking at the park so any overflow may lead to parking on the dirt roads. We feel like the boardwalk will primarily attract non-residents, similar to what is seen at the Lake Streek park. Residents around Lake Street Park complain about large parties generating noise, excessive traffic and additional trash - we don't want to see that happen to Fernwood Park.

It is common knowledge that Bird Island already faces many challenges with several incidents happening just over this past summer that lead to injury. We do not feel that adding a boardwalk so close and in swimmable distance to Bird Island is a safe or prudent idea.

Lastly, it seems like the cost to construct this boardwalk is extremely high and we feel that money could be used for better purposes, considering the overall Town budget.

Thank you for your consideration.

Anna and Will Headley
826 Oakdale Street

Dear Robert,

This is to follow up on my comments during the Zoom meeting last night. It is simply unconscionable that all members of the Parks Committee did not attend one of the two Fernwood Park charettes. How can they possibly be given any further leeway to push this project when they have not taken the opportunity to listen to the valid concerns of the adjacent neighbors? This is not only insulting but opens up a dangerous precedent. How can a non-elected committee be given this much decision-making power over my safety, quality of life and property value? And yes, this boardwalk threatens each of these areas.

I strongly believe this project is misguided at best and reckless at worst. I have taken the time to explain why on several occasions...in person, in writing and on Zoom. If my neighbors and I had been given the opportunity to provide such input at the conception of this project, the time and money expended by the committee could have been avoided. The continued chastisement for not valuing these volunteers and their efforts is unappreciated and completely unfair. I simply don't agree with them or with the proposed boardwalk.

One more thing about volunteerism...I believe in it and have participated in it fully throughout my lifetime. What I have learned is that such can require a huge time commitment and being unpaid does not imply the absence of responsibility, accountability and culpability. In fact, it comes with the territory.

I would like to request that the on-site Fernwood meeting be scheduled to include me as well as my fellow adjacent neighbors. I will not be available until sometime next month and will let you know specifically when I have more concrete plans. I realize this may create a delay but this is that important to me.

I know that this issue is consuming much of your time and energy; please know how much I appreciate your efforts. Please share this letter as appropriate.

Thanks,

Annamaye

Robert,

I want to echo Cathy Tegler's concerns and make a few points of my own.

1. It was very disappointing to hear yesterday how few, if any of the Parks Committee members attended the lengthy charettes that you were kind enough to schedule and lead. However, the very people who needed to hear our concerns didn't feel it important enough to attend. Such disregard for the neighbors concerns is what got us to this point of extreme disagreement in the first place. And the fact that numerous Committee members don't appreciate the linkage to Bird Island shows a complete lack of empathy and simple ignorance. That issue was a major discussion point in your charette presentations.
2. They are now going down the same path with the idea of a permanent structure to house kayaks and canoes. It looks horrible and the number of problems it would create are almost too numerous to cite. Please let that idea die quickly. The number of people benefited is quite small yet the problems it creates, and the minimal amount of rent/value to the Town is not worth it. Certainly not in Fernwood with the existing ramp activity.
3. The adjoining neighbors simply must be present for the Park walk-thru meeting, no matter how long it takes to schedule. The Committee caused this by not contacting us earlier and we now deserve direct input on the ground. There is simply no rush to get this plan to Council, let alone build anything.
4. While I appreciate Bob McKinley's repeated reminders of how long and hard the volunteer Committee members have worked on this, the fact is that the whole effort was fatally flawed from the beginning due to their failure to seek input from the adjoining residents – which should have been obvious. The Town needs to change how these Committee's operate and require them to overtly and immediately notify residents directly if a Town project is proposed to directly impact properties. The DRC does this for even minor variances, let alone something as significant as this. And Nora's response that "no notice was required" is insulting.
5. The Committee's failure to seek professional land planning advice from someone experienced in designing amenities for public parks with an active boat ramp is another fatal mistake. I can assure you that I'll be hiring such a qualified expert (among others) to provide live testimony as to the safety issues they're creating mixing the ramp traffic and such a huge pedestrian attraction. It's simply insane. And no matter how long or hard the Committee members think they've worked on this, the project is clearly beyond their technical capabilities and expertise. They don't appreciate the permitting issues, wetland impacts, safety concerns, parking complexities, law enforcement issues or traffic impacts, let alone the consequences to the neighbors or even the cost. And they don't seem to care. They can meet and talk about this for years and it won't make a difference if they don't seek the appropriate outside expertise. A group of volunteers like this, no matter how well intended, is simply not qualified for a project like this.
6. As I think you know by now, I intend to appeal every permit sought by the Town to construct anything close to resembling the boardwalk this Committee seems so enamored with. I will present expert testimony at all Council meetings on the subject and file administrative appeals at the County, SFWMD and State levels for all permits required. And if I don't prevail at the administrative levels I'll file a judicial challenge. I have already identified the necessary

consultants – who happen to be people I work with professionally all the time. And I have unlimited access to my own 300 plus attorneys statewide, including in Tallahassee, who file administrative appeals for a living. I'm prepared to expend far more than the Town is on this matter. The detrimental impact to my home of 37 years is in the hundred's of thousands of dollars and that's how much I'm willing to pay to stop it. While it's important for you to know all this, it's not what I want to happen. What Frank Krens proposed yesterday is along the lines of something that is achievable and worth pursuing. It's all that is needed and would benefit everybody. But Nora simply blew him off.

Anything you can do to lead this Committee in a better direction is appreciated. It will save all of us a lot of time and money. But I'm prepared to go that route if needed.

Thanks for your continued efforts.



James G. Willard
Partner

Shutts & Bowen LLP

300 South Orange Avenue, Suite 1600 | Orlando, FL 32801

Direct: (407) 423-3200 | Fax: (407) 849-7209

[E-Mail](#) | [Biography](#) | [V-Card](#) | [Website](#)

Good Morning Robert,

I feel I need to expound on what Annamaye brought up last night regarding lack of full P & R committee attendance at the Fernwood Park charettes. Am I mistaken or wasn't the point of the charettes for the committee to hear the neighbors concerns? I know unequivocally Sherry Cassidy did not attend either **one and** I believe there were possibly one, if not two, others. So pretty much **the charettes** did nothing more than give us more grief and anguish.

With that being said, we feel it imperative that Ron and myself are able to **attend** the on site committee meeting. Would you please pass on our request to not hold it next week as we will be **out of town** October 10-17? Not only are we neighbors that would be impacted on two sides of our property but my husband can provide valuable information regarding permitting and **construction** as this has been our business for over 30 years. I believe Annamaye won't be returning until sometime in **November**.

TY.

Regards,

Cathy Tegeler

Dear Parks and Rec Committee and Windermere Town Council;

My husband and I moved to Windermere in 1992 and fell in love with this little sleepy town with dirt roads nestled on the chain of lakes. We bought a boat to go with the house we rented and spent every weekend on the lakes. At that time you had to have a residential pass displayed on your dashboard of your car to park at Fernwood Park and if you or a guest didn't have one you would return to a ticket on your car. We also had a healthy "fear" or authoritative regard to the water patrol. We were often pulled over to check for working lights and proper life vests and were very disciplined about being compliant.

Over the years we have watched the lakes get more crowded, more dangerous, and more polluted, both with trash and noise pollution. For the past 10 years I have kayaked out to bird island and along the shores and picked up trash and have seen it get worse and worse. As an aviculture volunteer for Audubon Center for Birds of Prey, I now collect data on the bird population and nesting activity and feel even more invested than ever in this precious resource of our lakes and Egret Island. Egret Island is home to one of the rare incidents of Brown Coastal Pelicans that live inland year round and the fish enriched lakes and ecosystem on the island is the reason why.

I enjoy the dock as much as many of the other residents here in Windermere. I admit, when I need some quiet time I will keep walking if I see someone on the dock because it is definitely a quaint space. I will sometimes go to the bench area instead to sit or stretch if I am on a run. There are other options in town to go to if Fernwood Park dock is busy so I will often head over to Lake Down or Cypress Point down by Palmer Park. I have watched boat parades from both locations. I do see many more strangers at Palmer Park and Cypress Tree point and that feels natural and haven't had any problems. What has bothered me is when I see someone I do not recognize, calling for maintenance on the SeaDoos she is renting out to strangers and many of their friends are piled onto Fernwood Park dock and taking off rather dangerously from the down and flying in and out on Jet Skis.

I oppose building a larger Boardwalk at Fernwood Park because I feel it will only increase non residential traffic, bottleneck our boat ramp, create much more trash which will be even harder to fish out from under a boardwalk area, and attract some of the unseemly nighttime traffic and shenanigans. I don't know many long time residents like myself who are for this expanded boardwalk. We have all voiced our concern about it changing the very reason we moved to this town and once we open this door it may become impossible to put that jeannie back in the bottle. I would be okay with adding a few more park benches along the shoreline. I also feel that it would benefit the park to go back to the strict standards that they maintained during the early 90's ensuring residents to be able to use the ramp without the craziness of outside unauthorized use of non residents.

Thank you,

Lara Ibarra

Lara Ibarra
laralibarra@gmail.com
Cell: 407-719-4626

I live in Windermere near the elementary school on Bayshore Drive. My children and I are on the chain of lakes regularly. I wish to voice my opposition to the proposed Boardwalk at Fernwood Park and encroaching onto Lake Butler. Frankly, this is a terrible idea.

Fernwood Park is small town park that can barely accommodate the ramp and park visitation.

The addition of the proposed boardwalk will be a huge disservice to the residents of Windermere. We already have problems with Bird Island and this will only make the situation worse.

As the past chairman of the South Florida Water Management District, I understand the potential environmental impacts to the wetlands and outstanding Florida water quality of Lake Butler. I urge you to solicit the Mayor and Town Council members to VOTE NO to the proposed Boardwalk at Fernwood Park.

Thank you,

Dan O'Keefe
11068 Bayshore Drive
Windermere



November 9, 2020

Attention: Mr. James Willard, Mr. Ron Tegler and Mrs. Annamaye Clonts

Reference: Fernwood Park Master Plan, Town of Windermere

Dear Mr. Willard, Mr. Tegler and Mrs. Clonts:

This letter serves to outline our professional opinion regarding the proposed boardwalk design and associated site improvements for Fernwood Park located on Lake Butler in Windermere, Florida.

On Monday, October 26th we conducted a site visit to evaluate the current conditions of the park site and reviewed the proposed park design for a boardwalk of approximately 350 linear feet – see Exhibit 'A' for the proposed boardwalk improvement plan.

Based on our evaluation and discussion of the proposed elements, we are providing the following observations:

1. The public participation process as outlined in the Town of Windermere's Request for Proposals (RFP 2016-03 Landscape Architectural Services) that included a minimum of two (2) stakeholder meetings was not followed.

Due to this lack of public participation, interested stakeholders, including town residents and adjacent property owners, were not given the opportunity to provide input on the park master plan and preliminary design efforts. As such, the proposed design moved forward for a considerable time without input from those that are potentially impacted the most.

We would advise that stakeholder meetings be held as outlined in the original RFP to obtain stakeholder comments and feedback on the proposed park design prior to moving forward with potential site improvements

2. In reviewing the current park, we understand that its primary function is to serve as a boat ramp that provides access to Lake Butler for Town residents. Given the limited access to Lake Butler the boat ramp at Fernwood Park is heavily utilized. We also understand that the park is utilized by emergency response vehicles when there is an emergency situation on the lake. Given the small park size, there is a concern regarding the capacity of the park to accommodate additional users that a large boardwalk feature would generate both in terms of parking and vehicular access.

We would advise that when stakeholder meetings are held that they involve boat ramp users as well as emergency response professionals to better understand the current usage of the park and to better ascertain the capacity for additional park users that would occur as a result of the proposed boardwalk improvements.



Southwest FL Numbers	Orlando Area: 407-412-6156
Naples: 239-597-9500	Southeast FL: 954-903-4650
Ft. Myers: 239-772-4234	Tampa Bay: 813-949-2288

Central Park - Swings & Expansion

QUOTATION # 11051

TO: Windermere Public Works
630 Main Street
Windermere FL 34786
407-876-2563 x5325

Attn: Scott Brown
sbrown@town.windermere.fl.us

Date:	November 5, 2020
Ship Date:	Approx. 4-5 Weeks ARO
Terms:	Net 30 Days
F.O.B.:	Destination
Salesperson:	Tim Hill 407-412-6156
Shipped Via:	CC

Quantity	Description	Unit Price	Total
Superior Play Components			
1	#TFR0630 8' Single Post Swing Frame w/ 3 Bays (select color)	\$ 3,608.64	\$ 3,608.64
1	#90015108 2 Belt Seats w/ Chain	\$ 178.00	\$ 178.00
1	#90015130 2 Full Bucket Tot Seats w/ Chain	\$ 365.12	\$ 365.12
1	#BSIS-25T Inclusive Swing for 2-5 yrs. (Green w/ Tan Brace)	\$ 625.00	\$ 625.00
1	#BSIS-512T Inclusive Swing for 5-12 yrs. (Green w/ Tan Brace)	\$ 625.00	\$ 625.00
	Less 5% Discount (per Charlotte Co. S.B. Bid #15/16-602MP-R4)		\$ 5,401.76
			\$ (270.09)
	Shipping & Handling		\$ 5,131.67
			\$ 328.00
	Additional Preferred Customer Discount		\$ 5,459.67
	Total Delivered Superior		\$ (159.67)
			\$ 5,300.00
Action Play Systems			
2	#ADAHalfRamp Half Ramp System for 12" Border	\$ 500.00	\$ 1,000.00
	Less 10% Discount (per Charlotte Co. S.B. Bid #15/16-602MP-R4)		\$ (100.00)
	Shipping & Handling		\$ 900.00
	Total Delivered APS		\$ 270.00
			\$ 1,170.00
Cowart (1 Full Truckload)			
90	Kid Safe Engineered Wood Fiber (measured in cubic yards)	\$ 23.50	\$ 2,115.00
1	Weed Barrier (6' x 300' Roll)	\$ 225.00	\$ 225.00
	Less 10% Discount (per Charlotte Co. S.B. Bid #15/16-602MP-R4)		\$ 2,340.00
			\$ (234.00)
	Shipping & Handling		\$ 2,106.00
	Total Delivered Cowart		\$ 295.00
			\$ 2,401.00
Total Delivered Materials			\$ 8,871.00
Optional Installation			\$ 3,700.00
TOTAL PRICE			\$ 12,571.00

Price does not include any permits or associated fees, if applicable.
Price based on standard colors and valid for 30 days.

Optional Installation by Kennico, Inc. or others.

NOTE: Price includes removal/disposal of old swing and expanding border system (with city provided borders) to link 3 play areas together.

Thank you.



USER GROUP: 2-5 Years, 5-12 Years
RECOMMENDED CREW: 2-4 People

TOOLS REQUIRED:

- TT-45 Torx, 9/16" Hex, 3/4" Hex, 1/8", Allen, 1/4" Allen
- Level, Square
- Auger / Post Hole Digger / Shovel
- Drill Bits: 21/64"
- High Speed 3/8" Electric Drill with Clutch
- Hammer / Mallet

NOTE: Use of any other driver may result in damage to tool and/or hardware!

INSTALLATION TIME: 2 Hours

WEIGHT: 651 lbs.

CONCRETE REQUIRED: (28) 80lb. bags - 16.4 ft³
NOTE: Concrete must have a minimum rating of 2,500 psi and must be mixed per manufacturer's recommendations.

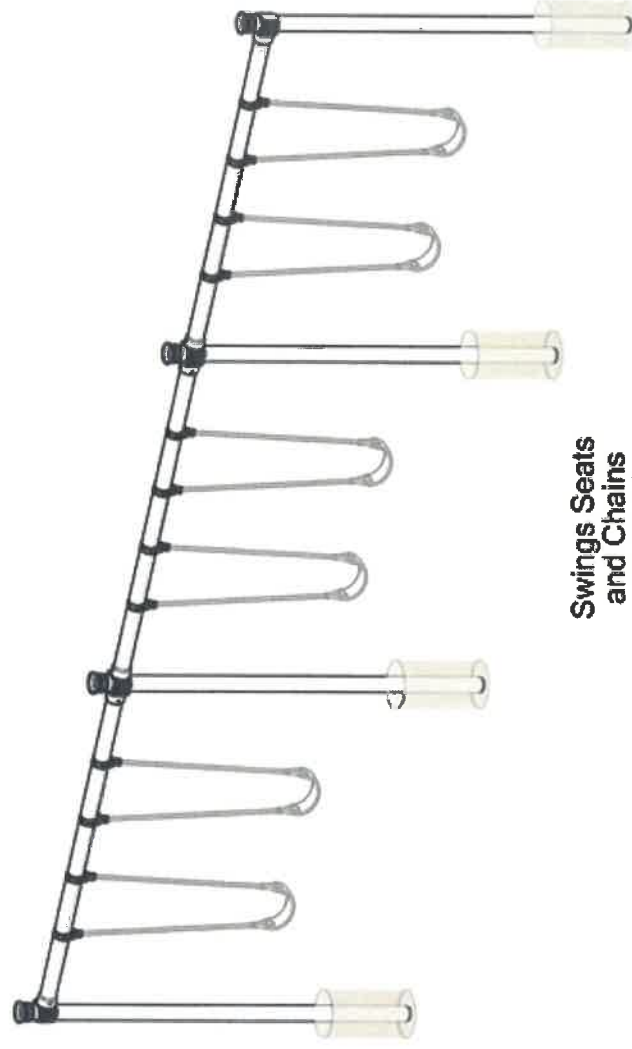

Swings Seats and Chains Ordered Separately

PRE-INSTALLATION CHECK:

Customer is responsible for verifying materials received by comparing received items with packing list. If any parts are missing or damaged, contact your local sales representative immediately.

Supplier is not responsible for items discovered missing after 72 hours from time of delivery.

Before beginning installation, all installers must read and understand the Installation Introduction manual as supplied. If you did not receive a copy, or if you have any questions regarding any information in the Installation Instructions or this Installation Guideline, contact your local sales representative.



ITEM	Part No.	QTY	DESCRIPTION
1	PST-0899XX	4	5" OD x 11 Ga. x 150" (Coated)
2	FAB-310818XX	3	5" OD 11 Ga. x 132" (COATED)
3	90215505XX	2	Fitting - 5 x 5 Saddle (Coated)
4	90215515XX	6	Fitting - 5 x 5 Receiver - (Coated)
5	HWB0610	16	Bolt 3/8" - 16 x 2-3/4" TORX Security with Patch SS
6	HWWR0185	32	Washer 3/8" ID x 7/8" OD General Purpose SS
7	HWN0098	16	Nut 3/8" - Nylock 300 S/S
8	HWS0016	12	Screw 1/2" - x 3/4" Allen Set
9	HWS0081	8	Screw 3/8" .16 x 1-1/4" Self-Tapping Torx w/Patch
10	1487	12	SWING HANGER 5" O.D.
10-1	157005	1	5" Top Clamp Half
10-2	157013	1	5" Bottom Clamp Half
10-3	800256	2	Belt - 3/8" x 2" CAR GD 5 (NOTE: FOR USE IN SWING HANGER ONLY)
10-4	804353	2	Nut - 3/8" Self Locking Hex (NOTE: FOR USE IN SWING HANGER ONLY)
10-5	801200	1	Bolt - 1/2" x 2 1/2" HH w/ 1" Thread (NOTE: FOR USE IN SWING HANGER ONLY)
10-6	817342	1	Washer - 1/2" Lockwasher SS
10-7	804055	1	Nut - 1/2" Hex SS
10-8	157010	1	Swing Hanger Pendulum Assy
10-9	811226	1	Bolt - 3/8" x 1" Shoulder Bolt (NOTE: FOR USE IN SWING HANGER ONLY)
11	CTG-10011XX	4	Post Cap 5" - Generic (Coated)

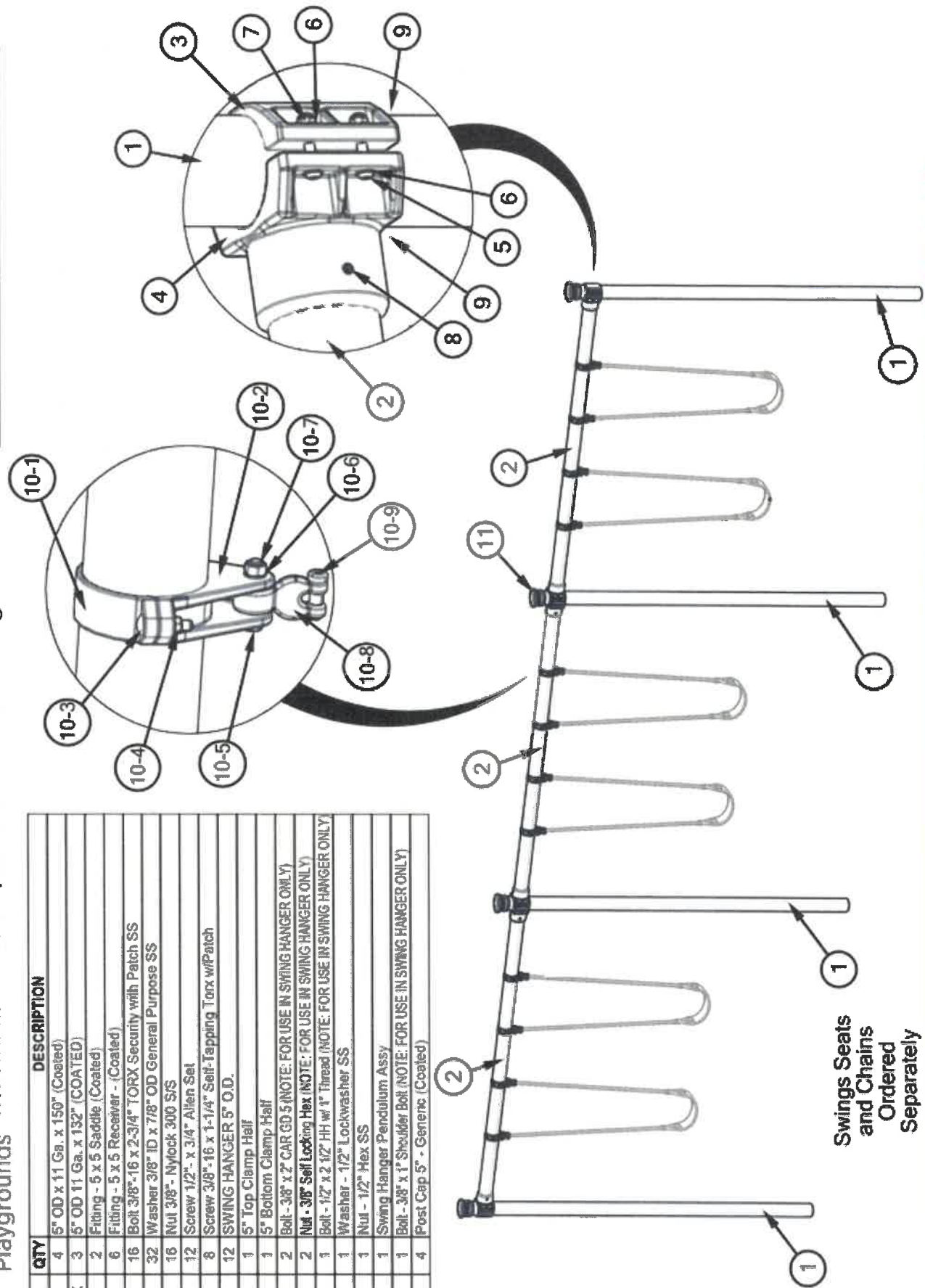

Swings Seats
and Chains
Ordered
Separately



STEP 1

Prepare footing holes. Refer to site plan drawing and site elevation drawing for placement of all support posts. Installer is responsible for proper location of all support posts. Footing hole spacing is shown below. Footing holes for support posts must be 18" diameter and 33" deep plus 12" surfacing. Place one block (not included) into bottom of each footing hole. If surfacing is less than 12", adjust footing hole depths as needed. See Detail 1-1 for footing hole detail. Center of top bar must be 96" above surfacing. **DO NOT ADD CONCRETE.** Footing holes will be completed at STEP 6. Proceed to STEP 2.

Detail 1-1

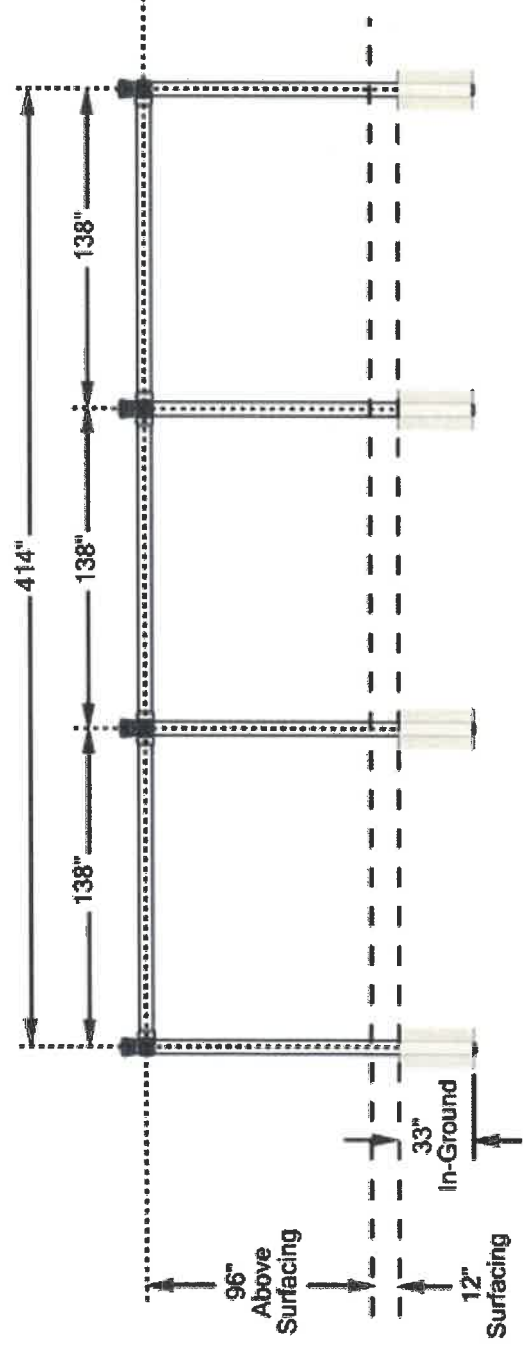
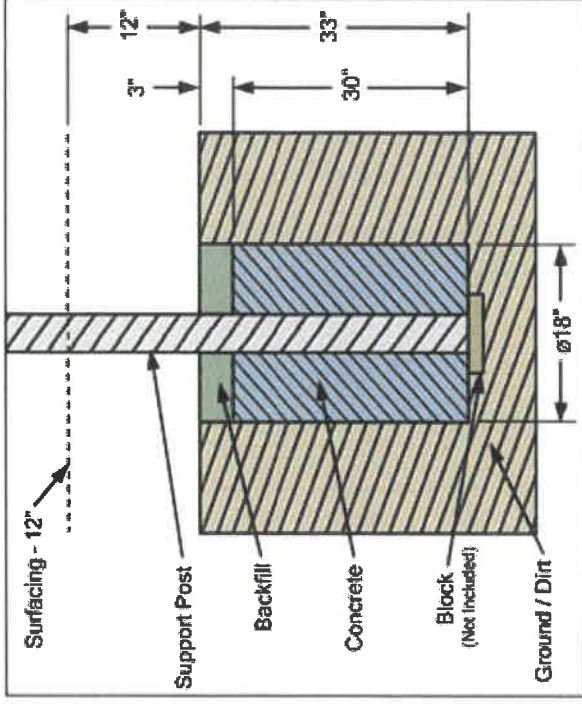



STEP 2

Mount saddles and receivers to end support posts. At each end post, position one (1) saddle fitting and one (1) receiver fitting. Center of receiver fitting should be 96" above surfacing. Receiver has two (2) set screws holes. Holes should point down and to the side. See measurement method at right. Secure fittings together with four (4) 3/8" x 2-3/4" security Torx, eight (8) 3/8" x 7/8" flat washers, and four (4) 3/8" Nylon lock nuts. Ensure gap on each side of fittings is equal. No more than two (2) threads of any bolts should extend past nuts. Use additional washers to reduce exposed threads. Tighten hardware to approximately 20 ft-lb (+/- 1 ft-lb). See Detail 2-1. Repeat for each end post. Mount one (1) post cap to top end of each post.

Detail 2-1

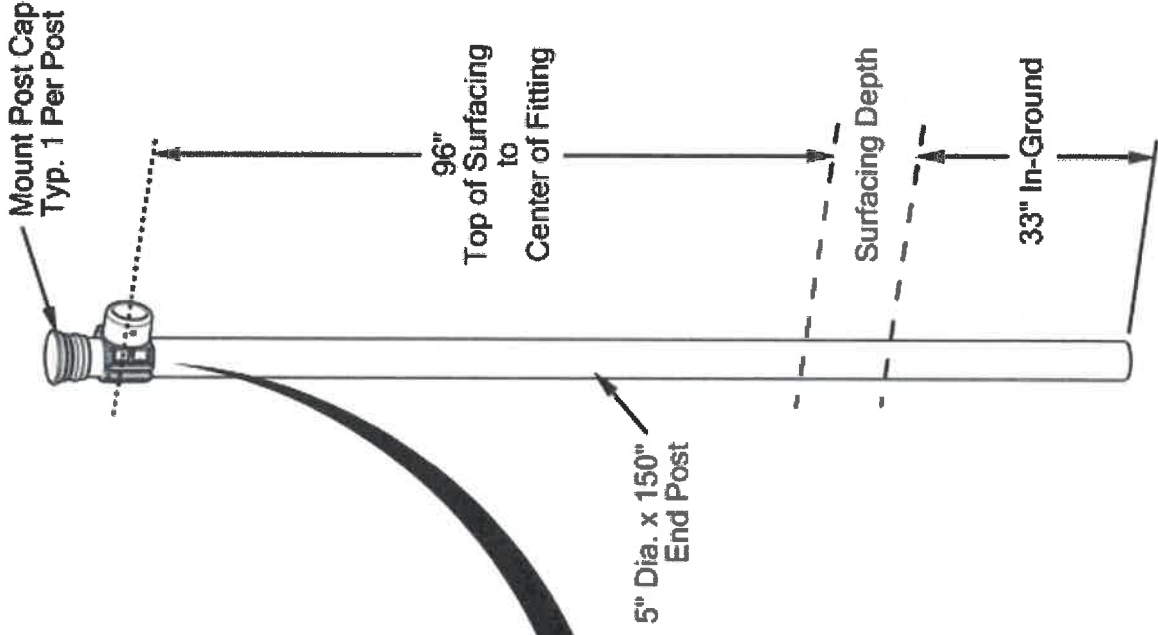
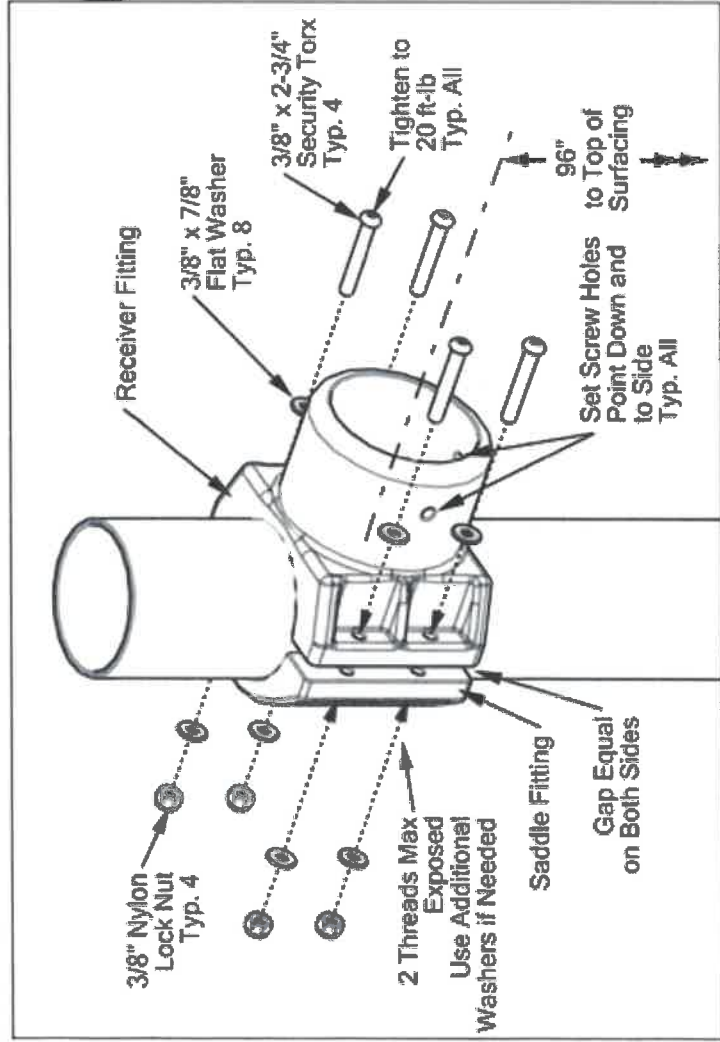



INSTALLATION GUIDELINE

STEP 3

Mount receivers on each side of middle support posts. At each middle post, position two (2) receiver fittings. Center of receiver fittings should be 96" above surfacing. Receiver has two (2) set screws holes. Holes should point down and to the side. See measurement method at right. Secure fittings together with four (4) 3/8" x 2-3/4" security Torx, eight (8) 3/8" x 7/8" flat washers, and four (4) 3/8" Nylon lock nuts. Ensure gap on each side of fittings is equal. No more than two (2) threads of any bolts should extend past nuts. Use additional washers to reduce exposed threads. Tighten hardware to approximately 20 ft-lb (+/- 1 ft-lb). See Detail 3-1. Repeat for each middle post. Mount one (1) post cap to top end of each post.

Detail 3-1

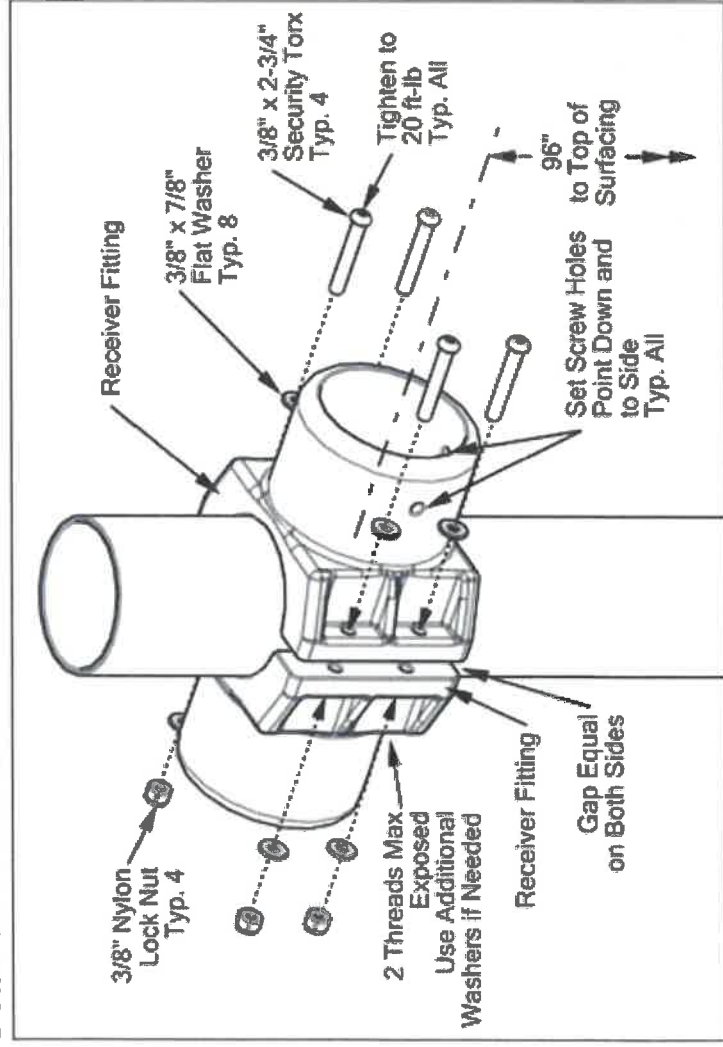

STEP 4

Mount top bars. Insert top bar ends into receiver fittings. Ensure ends of top bars seat fully into receiver fittings. At each receiver fitting, secure with two (2) 1/2" x 3/4" Allen set screws. Repeat for all receiver fittings. At bottom of each saddle fitting, drill one (1) 21/64" pilot hole into support post. Secure with one (1) 3/8" x 1-1/4" self-tapping security Torx. See Detail 4-1. At bottom of each receiver fitting, drill one (1) 21/64" pilot hole into support post. Secure with one (1) 3/8" x 1-1/4" self-tapping security Torx. See Detail 4-2.

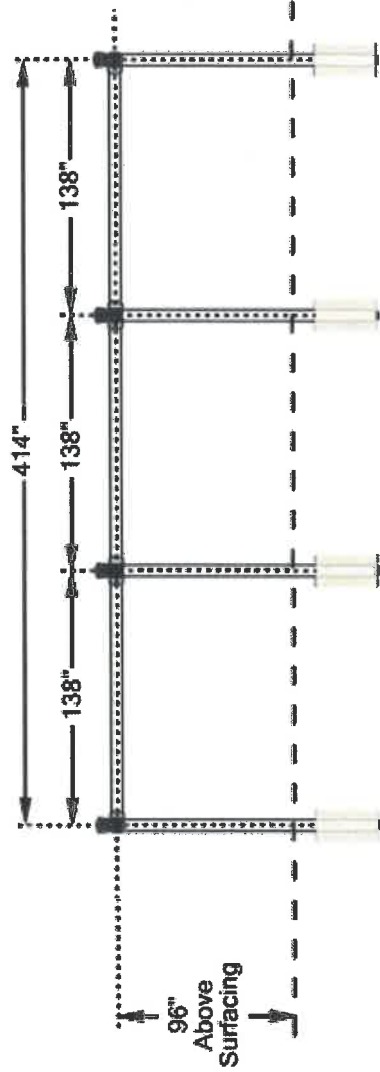

Detail 4-1

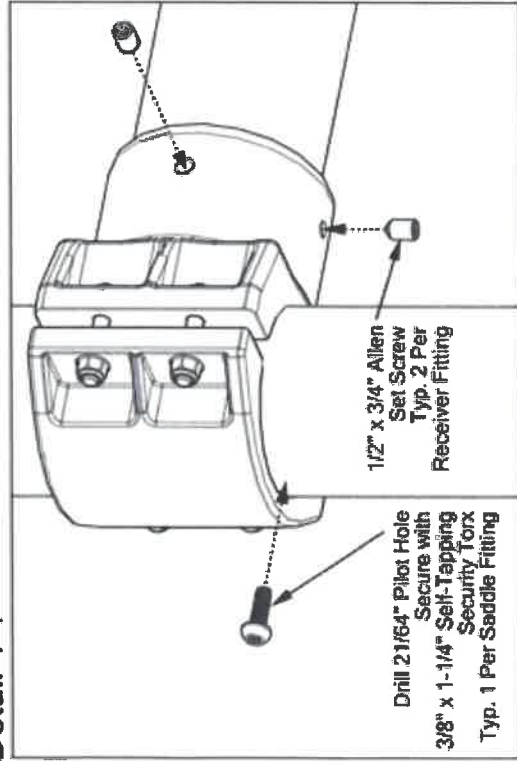

Detail 4-2

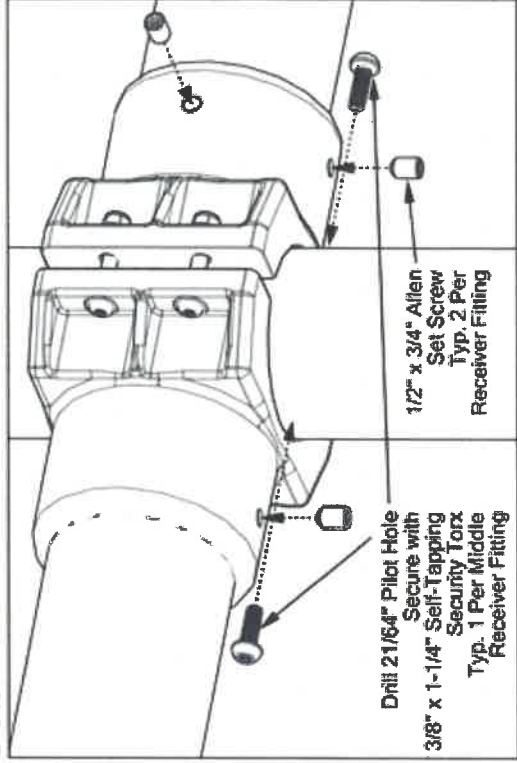



STEP 5

Mount swing hangers to top bars. Swing hanger spacing is shown below. Place top clamp half over top of bar. Place bottom clamp half under top bar. Secure with two (2) 3/8" x 2" carriage bolts and two (2) 3/8" lock hex nuts. Ensure gap on each side of clamps is equal. Tighten hardware to approximately 20 ft-lb(+/- 1 ft-lb). Secure pendulum to bottom clamp with one (1) 1/2" x 2-1/2" (1" thread) hex head bolt, one (1) 1/2" lock washer, and one (1) 1/2" hex nut. See Detail 5-1. Mount four (4) hangers per each top bar. Swing chain will be secured to pendulum with one (1) 3/8" x 1" Allen shoulder bolt.

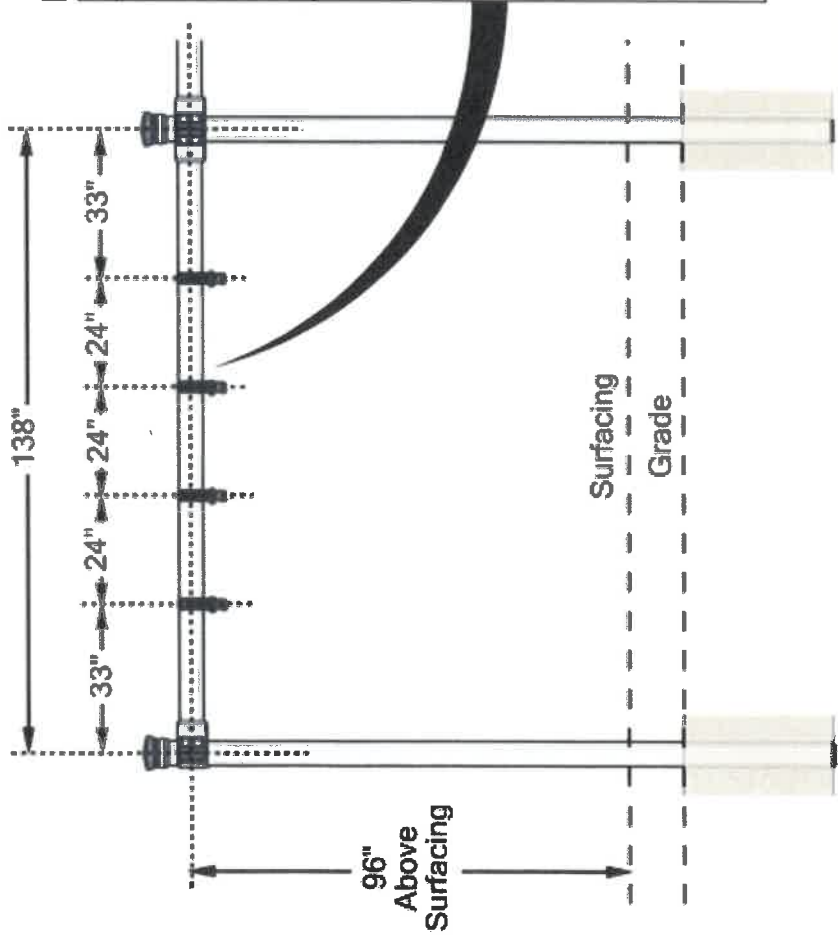

Detail 5-1

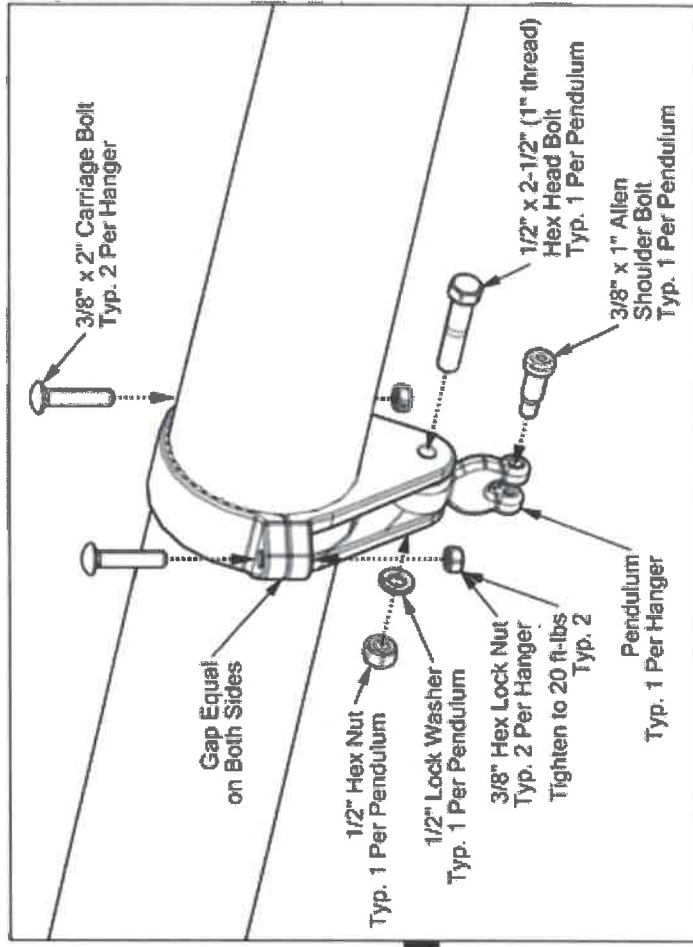

STEP 6

Complete setting of footing holes. Ensure support posts are plumb. Ensure blocks are beneath support posts. Ensure center of top bars are 96" above surface. Fill footing holes with concrete to within 3" from ground surface. Allow concrete to cure based upon manufacturer's instructions. Backfill footing holes with dirt, flush with grade. See Detail 6-1 for footing hole details. Do not install swings or chains until concrete is fully cured. Do not install swings or chains until play area is available for use. Check all connections and ensure structure is stable. All concrete must be fully cured before use of structure. Installation is complete. Place one (1) Age Appropriate Sticker (based upon swing style) on structure in a clearly visible location.

Detail 6-1

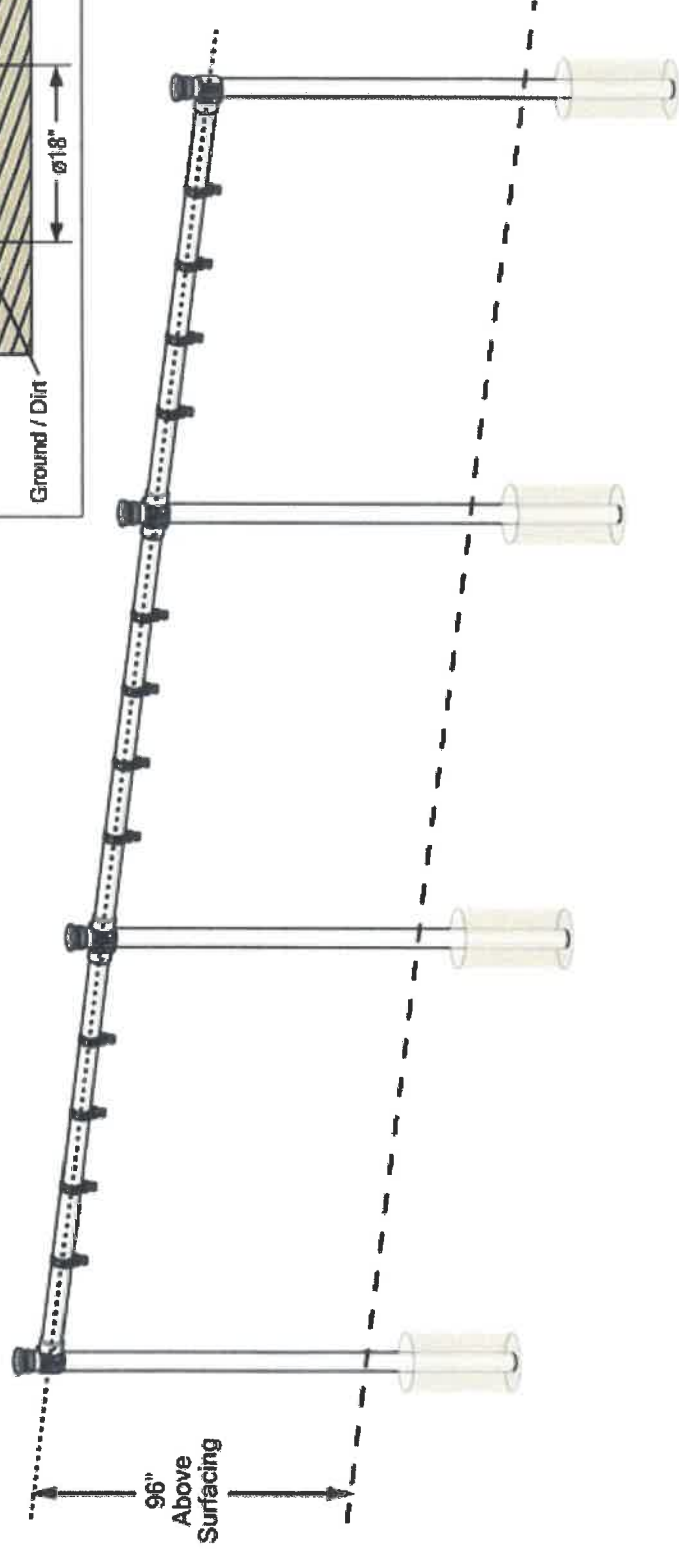
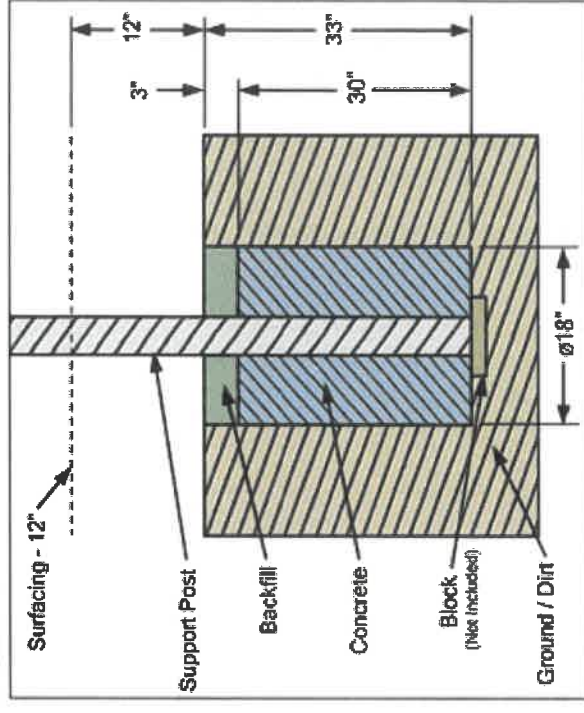



DOBSON'S WOODS AND WATER INC.

851 Maguire Road
Ocoee, FL 34761
407-841-0030
Fax: 407-843-7546
www.dobsonww.com

Registered Landscape Architects Landscape & Irrigation Contractors

SELLER AGREES TO FURNISH ALL LABOR AND MATERIALS INCIDENTAL TO THE FOLLOWING SPECIFICATIONS

AT: Town of Windermere Main St Windermere
Name Address City Zip Telephone

QTY	PLANTS - LABOR - OTHER MATERIAL	SIZE	EACH	TOTAL
	Scope of work: Installation of 2 Magnolias, 115 Viburnum Suspensum,			\$0.00
	Pine Bark Mulch and Irrigation to create a hedge along the Oakdale			\$0.00
	Side of Central Park.			\$0.00
				\$0.00
2	Magnolia	6" cal 16'-20'	\$2,875.00	\$5,750.00
115	Viburnum Suspensum	7gal 24"-36"	\$37.50	\$4,312.50
1	Irrigation		\$850.00	\$850.00
				\$0.00
				\$0.00
				\$0.00
				\$0.00
				\$0.00
				\$0.00
				\$0.00
				\$0.00
				\$0.00
				\$0.00
				\$0.00
				\$0.00
				\$0.00
				\$0.00
				\$0.00
				\$0.00
				\$0.00
				\$0.00
			TOTAL:	\$10,912.50

Buyer agrees to pay the contract in full upon completion of work.
Buyer agrees to pay seller the sum of twenty-five percent (\$2,728.13 cash) down-payment upon acceptance of contract.
Buyer agrees to pay seller for the foregoing labor and materials the sum of \$10,912.50 cash, less down payment.

Both parties agree that delinquent payment of this contract voids the guarantee. Any changes in above specifications must be agreed to by the parties in writing, both as physical change and as to price therefore. Both parties agree that the above constitutes the entire contract between them and that there are no other different understandings or agreements between them.

Dated at Orlando, Florida this Friday, October 30, 2020

We warrant our plant materials to be in healthy growing condition. We will replace ONCE any woody plants that fail to grown for a period of six months after planting. **NO WARRANTY ON LAWNS, ANNUALS, PERENNIALS, OR GROUND COVER.** Guarantee shall be null and void for plants damaged as a result of hail, frost, wind, lightning, lighting, lethal yellowing, neglect, or abuse. Sprinkler systems are guaranteed for a period of one year.

BY: _____
Seller

Buyer

Buyer

*If action is commenced to enforce payment, seller shall be entitled to recover attorney's fees and costs incurred as well as damages

*Past due accounts bear interest on the unpaid sum at the rate of 1 1/2% per month.



DOBSON'S WOODS AND WATER INC.

851 Maguire Road
Ocoee, FL 34761
407-841-0030
Fax: 407-843-7546
www.dobsonww.com

Registered Landscape Architects Landscape & Irrigation Contractors

SELLER AGREES TO FURNISH ALL LABOR AND MATERIALS INCIDENTAL TO THE FOLLOWING SPECIFICATIONS

AT:	Town of Windermere	Main St	Windermere	Zip	Telephone
	Name	Address	City		

QTY	PLANTS - LABOR - OTHER MATERIAL	SIZE	EACH	TOTAL
	Scope of work: INstallation of 2 Magnolias, 115 Viburnum Suspensum,			\$0.00
	Pine Bark Mulch and Irriaction to create a hedge along the Oakdale			\$0.00
	Side of Central Park.			\$0.00
				\$0.00
				\$0.00
2	Magnolia	4" Cal 12'-16'	\$1,275.00	\$2,550.00
115	Viburnum Suspensum	3gal 14"-16"	\$11.50	\$1,322.50
1	Irrigation		\$850.00	\$850.00
				\$0.00
				\$0.00
				\$0.00
				\$0.00
				\$0.00
				\$0.00
				\$0.00
				\$0.00
				\$0.00
				\$0.00
				\$0.00
				\$0.00
				\$0.00
				\$0.00
				\$0.00
				\$0.00
				\$0.00
				\$0.00
				\$0.00
				\$0.00
				\$0.00
				\$0.00
			TOTAL:	\$4,722.50

Buyer agrees to pay the contract in full upon completion of work.

Buyer agrees to pay seller the sum of twenty-five percent (\$1,180.63 cash) down-payment upon acceptance of contract.

Buyer agrees to pay seller for the foregoing labor and materials the sum of \$4,722.50 cash, less down payment.

Both parties agree that delinquent payment of this contract voids the guarantee. Any changes in above specifications must be agreed to by the parties in writing, both as physical change and as to price therefore. Both parties agree that the above constitutes the entire contract between them and that there are no other different understandings or agreements between them.

Dated at Orlando, Florida this Friday, October 30, 2020

We warrant our plant materials to be in healthy growing condition. We will replace ONCE any woody plants that fail to grown for a period of six months after planting. **NO WARRANTY ON LAWNS, ANNUALS, PERENNIALS, OR GROUND COVER.** Guarantee shall be null and void for plants damaged as a result of hail, frost, wind, lightning, lighting, lethal yellowing, neglect, or abuse. Sprinkler systems are guaranteed for a period of one year.

BY: _____
Seller

Buyer

Buyer

*If action is commenced to enforce payment, seller shall be entitled to recover attorney's fees and costs incurred as well as damages

*Past due accounts bear interest on the unpaid sum at the rate of 1 1/2% per month.

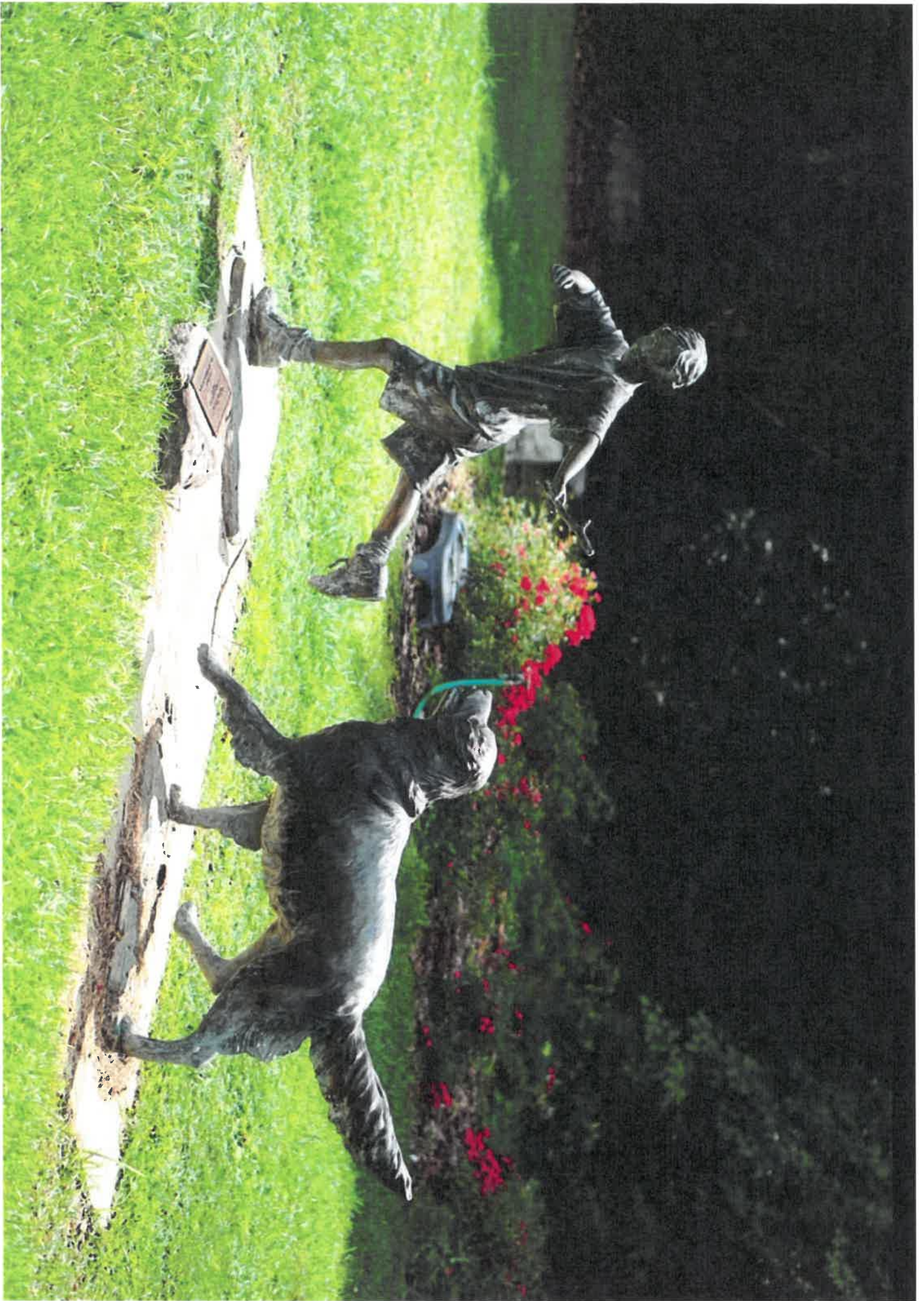

Town of Windermere

Parks and Recreation Committee Proposed Meeting Minutes/Notes October 8, 2020

Members Present: Doug Bowman, Nora Brophy, Shery Cassidy, Lesha Miller, Frank Krens, Tracy Mitchell

Others Present: Scott Brown, Bob McKinley, Robert Smith

Call to Order: The meeting was called to order by Nora Brophy. She noted that a quorum was present to approve official business.

Business Agenda

Public Resident Comments

- Stephen Withers – Planned Fernwood walkway is too big, and agrees to expand boat dock area rather than build walkway, and benches with lake view seating would be nice additions
- Jim Willard – Sees Bird Island as an ongoing issue, vehicle pedestrian impacts, and staying out of wetlands as issues for the opposed Fernwood walkway
- Anna Clonts – Opposed to Fernwood walkway impacting wetland areas
- Ron Tegler – Believes that cost to double size of Fernwood boat dock is roughly \$7k

Old Business/Events

- A. 19th Annual Run Among the Lakes – Nora indicated that many 2020 packets have not been picked up. She mentioned a tentative April 10, 2021 date for the 2021 event
- B. Halloween Candy Caravan Sat, Oct. 31st – Nora noted that she is working on a printable caravan route to include the Mayor and Police Chief. The caravan will meet at Town Hall at 9:45 am and follow the local route until Noon. The bags will be stuffed on October 28th by the Windermere Active Youth Committee (WAYS). The Police Foundation will be providing glow sticks in addition to the candy bags for the kids on the 31st. The group indicated a need to hire a photographer for the event. Lesha Miller made a motion to spend up to \$200 for a photographer, and this was seconded and approved by the committee. The committee agreed that Jennifer Roper is first choice and Bob will approach her to work that day.
- C. Kayak Storage – Frank Krens introduced George Poelker who developed the idea of kayak storage at one of the town parks. The goal of the initiative is to improve resident access for small non motorized watercraft on the lakes. Mr. Poelker estimated the cost of a kayak structure at around \$1500. Ideas of where to locate the kayak storage were tossed around with no consensus. The

committee asked Mr. Poelker and Frank Krens to develop more of a plan and come back to a meeting in the near future.

- D. Tennis – Doug Bowman noted that a town resident is still having problems with non resident tennis pros bumping residents on the courts. Doug mentioned that he had asked the resident to take pics of the pro so they can be identified, and possibly have the Town Manager counsel with them to stop this issue.
- E. Fernwood (Frank Krens) – Frank asked the committee to come back and consider a list of suggestions he had for the park. He noted that he agreed with some of Jim Willard’s ideas including the idea of expanding the boat dock. He asked that a copy of these suggestions be attached to the meeting minutes. Doug Bowman concurred that this would be the case per below – “Inputs to the Parks/Rec Meeting” addendum.

More discussion ensued around the plans for Fernwood Park. Doug Bowman asked to convene a working meeting at the park within the next 30 days pending coordinated scheduling. The committee agreed to do this to develop a workable plan.

New Business

- A. Minutes Approval – Meeting minutes from September were unanimously approved as submitted based on motion approvals.
- B. Liaison Reports – Bob McKinley had no formal Liaison report although he mentioned that a boathouse lease plan (near Palmer Park) will need to be developed at some point.
- C. Adjournment – The meeting was adjourned at approximately 6:30 p.m. The next regular meeting is scheduled for Thursday, November 12th at 5:00 p.m. in Town Hall.

Inputs to Parks/Meeting - Addendum

Frank Krens’ Recommendations:

1. Storm-water Control - Replace the berm that used to border the lake and that was removed years ago. This would help reduce run-off into the lake and provide a small elevation for a sitting / viewing platform. Modify the boat ramp and dock entrance area to restrict run-off. Integrate this into a comprehensive storm-water control / retention plan for the park, 7th Ave, and Butler Street.

2. Parking - Establish and clearly mark parking spaces, using RR ties and granite gravel.
3. Sitting / Lake View Area - Install on the berm a platform like Jim Willard's drawing shows, but separated from the dock by about 30 feet. Move it to the West, hugging the edge of the wetlands. It would be behind two of the trees and rest on top of the replaced berm. There is a mostly clear view of the lake from there, and shade during most of the day.
4. Landscaping - Install and maintain low-growing native plants along the shoreline in the wetlands.
5. Lake Debris - Clean up all the invasive species, dead trees, and the mess the whole length of the park and maintain it.
6. Boat Launch / Lake View - Extend the existing boat dock 20 feet to the West. This would double the space for temporary boat tie-ups and sitting / viewing. Add another bench or two.
7. Large / Occasional Lake View Area - Consider creating and maintaining a path along the lake for 50 - 100 feet west of the sitting / viewing platform, with a few places for people to put chairs where there is a clear view of the lake. This would be a low-cost way to provide lots of viewing space for the boat parade. Make it clear where the path ends and that further passage is prohibited.
8. Adopt-a-Park Program - Consider an "Adopt a Park" program for Fernwood and other Town parks. Other towns and counties (including New Smyrna Beach and Orange County – see links) have done that with success.

<https://www.orangecountyfl.net/CultureParks/AdoptAParkProgram.aspx#.X379sC9h2qA>

<https://www.cityofnsb.com/1064/Adopt-a-Park>

9. George Poelker's Kayak Storage Rack

Questions and Concerns:

1. Will Fernwood be used as a storm debris transfer station again?